



- CHEMICAL RESISTANT
- SELF-CLEANING
- FLEXIBLE
- HYGIENIC

Corroflon

CONVOLUTED PTFE LINED HOSE

Contents

Front Cover	Page 1
Contents	Page 2
PTFE - The Optimum Choice For Hose Linings	Page 3
Aflex Hose and Corroflon	Page 4
Corroflon Temperatures, Pressures & Flow Rates	Page 5
Corroflon Sizes, Grades, Bend Radius and Dimensions	Page 6
Corroflon Sizes, Grades, Pressure Ratings and Weights	Page 7
Corroflon Special Usage Conditions	Page 8
Quality Assurance Certification & Approvals and Hose Testing	Page 9
How to Order Corroflon	Page 10
Corroflon Part Number System	Page 11
<u>HOSE</u>	
Corroflon Hose Liners	Page 12
Corroflon Hose Braids (and Electrical Continuity)	Page 13
Corroflon Rubber Covers	Page 14
Corroflon External Protection Systems	Page 15
<u>FLANGE FITTINGS</u>	
Flange Fittings, Non-Lined	Page 16
Flange Fittings, PTFE Lined	Page 17
<u>CAM AND GROOVE FITTINGS (CAMLOCKS)</u>	
Female Cam & Groove Fittings, PTFE Lined and Not Lined	Page 18
Male Cam & Groove Fittings, PTFE Lined and Not Lined and Cam Male-to-Flange Adaptors, PTFE Lined	Page 19
<u>SANITARY (TRICLOVER) FITTINGS</u>	
Mini Sanitary & Sanitary Triclover Fittings, PTFE Lined	Page 20
Mini Sanitary & Sanitary Triclover Fittings, Not Lined	Page 21
90° Elbow Sanitary Triclover Fittings, Not Lined	Page 22
<u>HYGIENIC FITTINGS (EUROPEAN)</u>	
DIN11851 Male & Female Fittings, PTFE Lined and DIN11851 Female Fittings, Non-Lined	Page 23
SMS and RJT Female Fittings, PTFE Lined	Page 24
<u>BSP, NPT & JIC THREADED FITTINGS (Not Lined)</u>	
NPT & BSPT Fixed Male and NPT Fixed Female Fittings	Page 25
BSP 60° Cone Seat Female Fittings and Lug-Type Female Fittings	Page 26
37° JIC Female Fittings & NPT Male or Female Unions	Page 27
<u>PTFE Dip Pipes</u>	
PTFE Dip Pipes, Straight or 90° Elbow	Page 28
<u>90° ELBOW FITTINGS</u>	
90° Elbow Fittings, PTFE Lined and Non-Lined	Page 29
<u>HEAT JACKETED HOSE ASSEMBLIES</u>	
Steam Heated Hose Assemblies (CH Grade)	Page 30
Electrically Trace Heated Hose Assemblies (ETH Grade)	Page 31
<u>CORROFLON STANDARD LABELLING, STREAMLINE TAGGING & COLOUR CODING</u>	
Page 32	
<u>CORRECT HOSE CONFIGURATION & LENGTH CALCULATIONS</u>	
Bend Radius	Page 33
Abrasion & Torque	Page 34
Length Calculation	Page 35
<u>CONDITIONS OF SALE</u>	
Pages 36 & 37	

PTFE - The Optimum Choice For Hose Linings

Section from a PTFE Molecule,
16 Angstrom Units long.

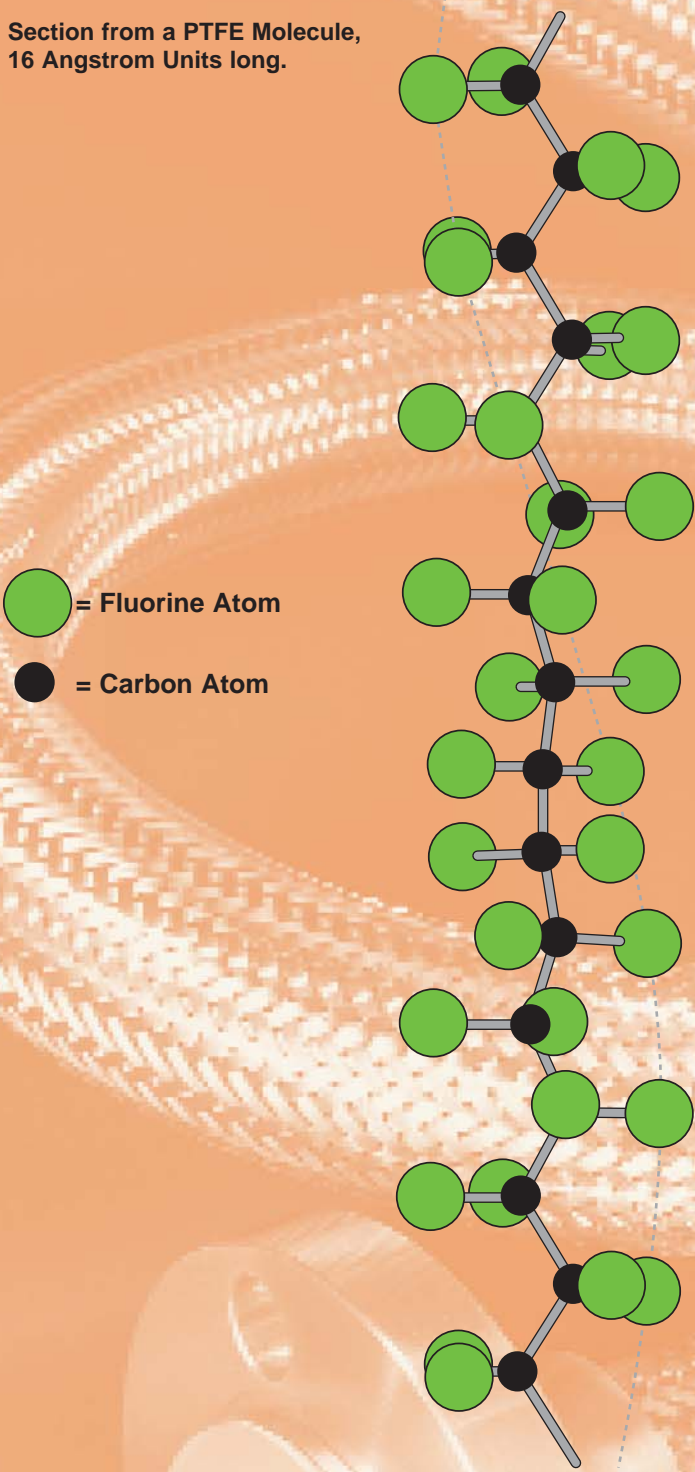

PTFE, or Polytetrafluoroethylene, comprises long-chain molecules of carbon atoms, each linked to two fluorine atoms.

The fluorine atoms provide a helical spiral which surrounds the carbon chain and protects it.

It is this structure which creates the unique properties for which PTFE is well-known.

Excellent Chemical Resistance

PTFE is renowned as the most chemically resistant material known. Only a very few, very unusual substances and conditions can affect it, like Fluorine gas at high temperature and pressure and Liquid, boiling sodium metal.

PTFE lined hoses can therefore be used for a wider variety of chemicals than any other hose type, making it the ideal choice for very corrosive chemical applications and multi-product applications.

Non-Stick Surface

The use of PTFE as a surface for cookware products has demonstrated to the world how easily cleanable PTFE surfaces are.

This means that PTFE lined hoses can be purged 100% clean more quickly, easily and reliably than any other type of hose.

Excellent Temperature Range

The cookware application also demonstrates another of PTFE's many attributes - temperature resistance. PTFE itself can be used as a hose liner at temperatures from -150°C up to $+260^{\circ}\text{C}$, dependent upon the hose design and the application conditions.

This is the widest temperature range of any rubber or plastic hose lining material.

Hose Design

The only issue with PTFE as a hose lining material is the best way it can be integrated in to the hose design. This is where Aflex Hose have a proven record of success over the last 30 years.

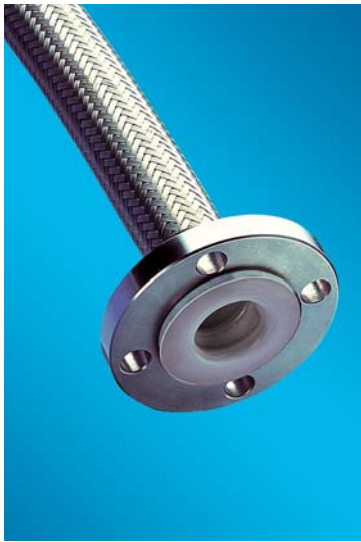

Aflex Hose and CORROFLON

The World's Leading Manufacturer of PTFE Flexible Hose

Aflex Hose pioneered the concept of PTFE lined flexible hose for the transfer of process fluids more than 30 years ago.

Corroflon convoluted bore and Bioflex, Corroline and Pharmaline smoothbore hose, all manufactured and supplied by Aflex, are used by major Chemical, Pharmaceutical and Food companies worldwide.

Over the years, hundreds of thousands of custom-built hoses have been designed and built to cope with the most difficult of operating conditions, and we have continuously developed and expanded our product range to meet increasingly stringent customer demands.

Corroflon

Convoluted, Reinforced PTFE Lined Hose

Corroflon was launched in 1978 and, since then, has been continually updated and improved. Now it is the industry-standard convoluted flexible PTFE hose for major chemical, pharmaceutical and food companies worldwide.

The key to Corroflon's success lies in its design and build quality, which guarantees a long, safe and reliable service life.

Corroflon's design differs from every other convoluted PTFE hose on the market, which results in distinctive and measurable performance and safety advantages.

Firstly, Corroflon will give better cleanability and drainability than any other convoluted PTFE hose on the market. This is because Corroflon is designed and manufactured in such a way that the angle of the convolutions is extremely shallow - 80° to 120°, compared with only 45° to 65° in other convoluted hose designs.

Secondly, Corroflon is the only PTFE lined convoluted hose on the market to be fully kink and vacuum resistant at high pressures and temperatures. This is because Corroflon's design incorporates a thick section external helical reinforcement wire which gives the radial support necessary to ensure maximum strength, whilst maintaining optimum flexibility and cleanability. The helix wire is welded directly to the end fittings at each end, ensuring security of attachment and electrical continuity.

And thirdly, Aflex is the only PTFE hose manufacturer to guarantee a minimum PTFE liner thickness of 1.5mm for hose sizes 1" and above, which ensures sufficient strength to prevent the tube from being internally pressurised from a sine wave shape into an extended square wave shape, which would lead to porosity, and eventually premature failure of the tube. This thick wall liner also minimises permeation, and is extended through the end fittings to give an uninterrupted clean flow of fluid through the fitting.

Corroflon GP PTFE Hose

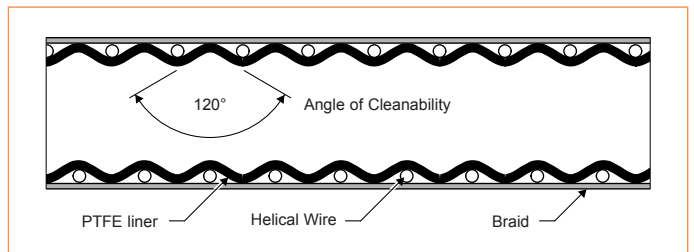

Typical Convoluted PTFE Hose

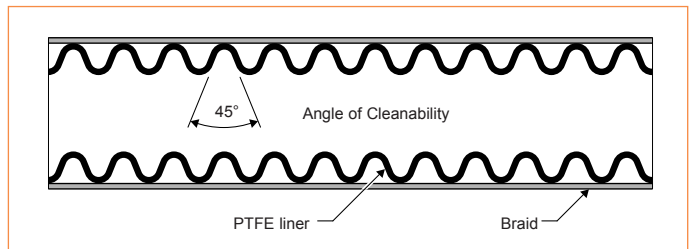

Corroflon GP, SS Hose and PTFE Lined Flange Fitting

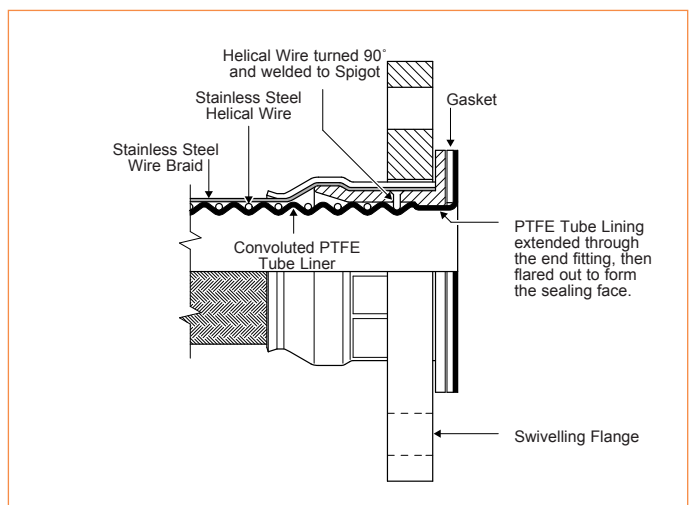

Corroflon Specifications.

Temperatures, Pressures & Flow Rates

Maximum Working Pressure (MWP) Variation with Temperature:

Hose with SS Braid as per Graph.

Hose with PB Braid, pressure as listed (Page 7) from -30°C to +80°C and 50% less from 80°C to 100°C.

Hose with RC, FP and SI grades as per Graph, BUT only within the temperature range for the particular grade of rubber cover, as given below.

Maximum Operating Temperatures (Internal Fluid Only) for different hose grades:

SS	-73°C to +260°C
PB	-30°C to +100°C
SS,RC & SS, FP	-40°C to +140°C
SS, SI	-73°C to +224°C
KYB	-40°C to +120°C

(Subtract 20°C from the above maximum temperature limits if the temperature is external to the hose).

Temperature & MWP Graph for Corroflon GP, SS and AS, SS

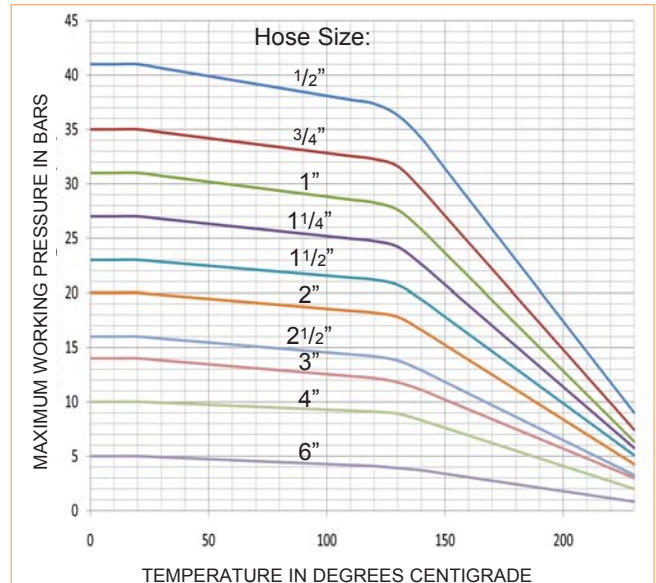

Temperature vs Vacuum

All sizes of Corroflon GP,SS and AS, SS are usable at full vacuum up to 130°C up to 2". Above this, the vacuum resistance should be reduced 1% for every degree above 130°C.

Other grades the same, BUT ONLY within the temperature limits for the particular hose grade.

Flow Rates

- For maximum flow rates, it is better to use the smoothbore Bioflex hose if possible, because the convoluted bore of Corroflon creates turbulent flow, which reduces flow rates.

Corroflon Hose - Flow Rate Calculation

If it is required to determine the flow rate of a particular hose assembly, or if it is required to determine the pressure required to generate a certain flow rate, then this can sometimes be approximately calculated by the Corroflon supplier.

It should be noted that calculations can only be made for fluids with a viscosity equal to water, and for hose assemblies with PTFE lined end fittings (no bore restrictions at the ends of the hose).

The following information should be given to the supplier:

To calculate the Flow Rate in Cubic Metres per Hour:

- Pressure in Bars at the Entry into the Hose Assembly
- Pressure in Bars at the Exit from the Hose Assembly $\left. \begin{matrix} \text{ } \\ \text{ } \end{matrix} \right\}$ (Subtracted to calculate Pressure Drop over the Hose Length)
- The hose configuration (roughly straight, or 33% Bends, or 66% Bends, or 100% Tightly Coiled)

OR To Calculate the Pressure Drop in bars over the length of the Hose Assembly:

- Required Flow Rate in Cubic Metres per Hour
- The hose configuration (roughly straight, or 33% Bends, or 66% Bends, or 100% Tightly Coiled)

Whistling

A 'whistling' noise may be created by turbulent flow when steam or other gasses are passed through a Corroflon hose at high flow rates. In such applications, Bioflex hose represents an alternative option which eliminates this problem.

Corroflon Sizes, Grades, Bend Radius and Dimensions

Nominal Hose Bore Size		Bore Inside Convolutions		Corroflon Grade (Braid & Cover)	PTFE Liner Tube Wall Thickness		O/D of Tube, Braid or Rubber		Minimum Bend Radius		* Maximum Continuous Hose Length	
in	mm	in	mm		in	mm	in	mm	in	mm	Feet	Metres
1/2	15	0.440	11.2	TO	0.05	1.4	0.63	16.1	1 1/2	38	100	30
				SS			0.70	17.8	1 1/2	38	100	30
				PB			0.80	20.4	1 1/2	38	100	30
				SS,RC/FP			0.90	22.8	2 1/4	57	100	30
				RC,SI			0.90	22.8	2 1/4	57	100	30
				KYB			0.76	19.3	1 1/2	38	100	30
3/4	20	0.620	15.7	TO	0.05	1.4	0.85	21.5	2	51	100	30
				SS			0.91	23.2	2	51	100	30
				PB			1.02	25.8	2	51	100	30
				SS,RC/FP			1.11	28.2	3	76	100	30
				RC,SI			1.11	28.2	3	76	100	30
				KYB			0.97	24.7	2	51	100	30
1	25	0.847	21.5	TO	0.06	1.5	1.08	27.4	2 3/4	70	100	30
				SS			1.14	29.1	2 3/4	70	100	30
				PB			1.25	31.7	2 3/4	70	100	30
				SS,RC/FP			1.34	34.1	4 1/4	105	100	30
				RC,SI			1.34	34.1	4 1/4	105	100	30
				KYB			1.20	30.6	2 3/4	70	100	30
1 1/4	32	1.080	27.5	TO	0.06	1.5	1.45	36.8	3 1/4	82	100	30
				SS			1.53	38.8	3 1/4	82	100	30
				PB			1.72	43.6	3 1/4	82	100	30
				SS,RC/FP			1.72	43.8	4 3/4	123	100	30
				RC,SI			1.72	43.8	4 3/4	123	100	30
				KYB			1.57	40.0	3 1/4	82	100	30
1 1/2	40	1.250	32.0	TO	0.06	1.5	1.65	42.0	4	100	100	30
				SS			1.74	44.1	4	100	100	30
				PB			1.92	48.8	4	100	100	30
				SS,RC/FP			1.93	49.1	6	150	100	30
				RC,SI			1.93	49.1	6	150	100	30
				KYB			1.78	45.2	4	100	100	30
2	50	1.690	43.0	TO	0.07	1.8	2.11	53.5	5 1/2	140	100	30
				SS			2.19	55.6	5 1/2	140	100	30
				PB			2.37	60.3	5 1/2	140	100	30
				SS,RC/FP			2.38	60.6	8 1/4	210	100	30
				RC,SI			2.38	60.6	8 1/4	210	100	30
				KYB			2.23	56.7	5 1/2	140	100	30
2 1/2	65	2.120	54.0	TO	0.07	1.8	2.75	69.8	7	178	65	20
				SS			2.83	71.9	7	178	65	20
				PB			3.01	76.6	7	178	65	20
				SS,RC/FP			3.03	76.9	10 1/2	267	65	20
				RC,SI			3.03	76.9	10 1/2	267	65	20
				KYB			2.87	73.0	7	178	65	20
3	80	2.500	64.0	TO	0.07	1.8	3.27	83.0	9	230	65	20
				SS			3.37	85.7	9	230	65	20
				PB			3.53	89.8	9	230	65	20
				SS,RC/FP			3.57	90.7	13 1/2	345	65	20
				RC,SI			3.57	90.7	13 1/2	345	65	20
				KYB			3.39	86.2	9	230	65	20
4	100	3.860	98.0	TO	0.10	2.5	4.17	106.0	11 3/4	300	32	10
				SS			4.28	108.7	11 3/4	300	32	10
				PB			4.44	112.8	11 3/4	300	32	10
				SS,RC/FP			4.48	113.7	17 3/4	450	32	10
				RC,SI			4.48	113.7	17 3/4	450	32	10
				KYB			-	-	-	-	-	-
6	150	5.250	130.0	TO	0.12	3.0	5.75	146.0	23 3/4	600	28	8
				SS			5.87	149.0	23 3/4	600	28	8
				PB			-	-	-	-	-	-
				SS,RC/FP			6.06	154.0	35 1/2	900	28	8
				RC,SI			6.06	154.0	35 1/2	900	28	8
				KYB			-	-	-	-	-	-

*Longer lengths may be available to special order if needed

Corroflon Sizes, Grades, Pressure Ratings & Weights

Nominal Hose Bore Size		Bore Inside Convolutions		Corroflon Grade (Braid & Cover)	Maximum Working Pressure of Hose		Burst Pressure		Weight per Unit Length	
in	mm	in	mm		Bar	psi	Bar	psi	Kg/Mtr	lb/ft
1/2	15	0.440	11.2	TO	6	87	24	350	0.21	0.14
				SS	41	595	450	6525	0.33	0.22
				PB	31	450	150	2175	0.26	0.17
				SS,RC/FP	41	595	450	6525	0.49	0.33
				RC,SI	41	595	450	6525	0.49	0.33
				KYB	15	215	61.5	890	0.23	0.15
3/4	20	0.620	15.7	TO	5	70	20	290	0.29	0.19
				SS	35	505	240	3480	0.45	0.30
				PB	26	375	105	1520	0.36	0.24
				SS,RC/FP	35	505	240	3480	0.56	0.38
				RC,SI	35	505	240	3480	0.56	0.38
				KYB	13	190	52.5	760	0.31	0.21
1	25	0.847	21.5	TO	4.5	65	18	260	0.45	0.30
				SS	31	450	200	2900	0.70	0.47
				PB	23	334	93	1350	0.56	0.38
				SS,RC/FP	31	450	200	2900	0.98	0.66
				RC,SI	31	450	200	2900	0.98	0.66
				KYB	11	160	46.5	675	0.49	0.33
1 1/4	32	1.080	27.5	TO	4	58	16	230	0.53	0.36
				SS	27	390	180	2610	0.82	0.55
				PB	20	290	81	1175	0.66	0.44
				SS,RC/FP	27	390	180	2610	1.12	0.75
				RC,SI	27	390	180	2610	1.12	0.75
				KYB	10	145	40.5	585	0.57	0.38
1 1/2	40	1.250	32.0	TO	3.5	50	14	205	0.97	0.65
				SS	23	335	120	1740	1.50	1.01
				PB	17	245	69	1000	1.20	0.80
				SS,RC/FP	23	335	120	1740	1.90	1.27
				RC,SI	23	335	120	1740	1.90	1.27
				KYB	9	130	34.5	500	1.05	0.70
2	50	1.690	43.0	TO	3	44	12	175	1.36	0.91
				SS	20	290	100	1450	2.10	1.41
				PB	15	215	60	870	1.68	1.13
				SS,RC/FP	20	290	100	1450	2.72	1.82
				RC,SI	20	290	100	1450	2.72	1.82
				KYB	8	115	30	435	1.47	0.99
2 1/2	65	2.120	54.0	TO	2.5	36	10	145	1.68	1.13
				SS	16	230	70	1015	2.58	1.73
				PB	12	175	48	695	2.06	1.38
				SS,RC/FP	16	230	70	1015	3.10	2.08
				RC,SI	16	230	70	1015	3.10	2.08
				KYB	6	87	24	350	1.81	1.21
3	80	2.500	64.0	TO	2	29	8	115	2.14	1.43
				SS	14	205	60	870	3.29	2.20
				PB	10	145	42	610	2.63	1.76
				SS,RC/FP	14	205	60	870	3.95	2.65
				RC,SI	14	205	60	870	3.95	2.65
				KYB	5	73	21	305	2.30	1.54
4	100	3.860	98.0	TO	1.5	22	6	87	3.18	2.13
				SS	10	145	40	580	5.05	3.38
				PB	8	115	30	435	3.98	2.67
				SS,RC/FP	10	145	40	580	6.12	4.10
				RC,SI	10	145	40	580	6.12	4.11
				KYB	-	-	-	-	-	-
6	150	5.250	130.0	TO	0.75	11	3	44	6.50	4.36
				SS	5	73	20	290	10.00	6.70
				PB	-	-	-	-	-	-
				SS,RC/FP	5	73	20	290	12.00	8.04
				RC,SI	5	73	20	290	12.00	8.04
				KYB	-	-	-	-	-	-

Corroflon Hose: Special Usage Conditions

Cleaning & Sterilising Systems - CIP, SIP and Autoclave

CIP & SIP – PTFE liner tubes are chemically resistant to all CIP, SIP and Autoclave conditions. The primary consideration is whether the cleaning and purging cycle is likely to develop an electrostatic charge on the internal surface of the liner, in which case AS (Anti-Static) grade hose is required.

AS grade hose and Electrostatic charge generating systems are fully described in the hose liner section.

CIP systems using high electrical resistivity solvents like Toluene will require AS grade hose.

Another electrostatic generation problem arises when wet steam is used, or when the cleaning fluids or WFI are purged out of the line using nitrogen, compressed air or another gas, because droplets of liquid or water in the gas then generate a multi-phase condition until they are cleared out, which will generate a static charge, and so will require AS grade hose.

In static generating applications where AS grade hose is not acceptable due to the black PTFE liner, alternative solutions are available – please consult Aflex Hose for advice.

Autoclave – Autoclave sterilisation does not normally involve any high flow rates through the hose bore, so static generation is not a problem. Aflex hose grades GP and AS, with SS or HB braids are fully resistant to all autoclave conditions throughout the service life of the hose.

The rubber covered grades EPDM, (RC) and Silicone Rubber (RC, SI) are able to withstand at least 100 x 30 minute autoclave cycles at relatively high autoclave temperatures (121°C, 250°F or 135°C, 275°F). Consult Aflex Hose for more specific information.

PTFE Hose-Use with Alkali Metals, Halogens and Halogen containing Chemicals

PTFE hose liners react chemically with Fluorine, Chlorine Trifluoride and molten Alkali Metals.

When PTFE lined hose is used to carry Chlorine or Bromine, either as gasses or fluids, they will diffuse into and through the PTFE liner wall thickness. Trace quantities will then combine with atmospheric moisture to corrode any braid/rubber outer coverings.

Heavily halogenated chemicals, like Hydrogen Fluoride, Hydrogen Chloride, Phosgene (Carbonyl Chloride) Carbon Tetrachloride and other organic chemicals with a high halogen content can also be absorbed and transmitted through the PTFE liner tube.

Other “Penetrating” Fluids and Gases

Sulphur Trioxide, Methyl Methacrylate, Caprolactam and Glacial Acetic Acid are some other chemicals which can be absorbed and transmitted through the PTFE liner tube wall.

Generally, however, as a hydrophobic (non-wetting) material, PTFE is very resistant to the absorption of chemicals. In some cases, PTFE has superior resistance to diffusion, for example to the diffusion of automotive fuels, in comparison with all other plastics and rubbers.

Gas/Fluid Cycling

There are some applications where the fluid passing through the hose turns into a gas, then back into a fluid, then into a gas etc, in a cyclic sequence.

This is normally associated with changes in temperature and/or pressure. For complex reasons these conditions are extremely damaging to the hose liner, whatever material it is made from.

For example, hoses are sometimes used to pass steam, water, steam etc into rubber moulding presses, in order to heat the mould, then rapidly cool it before reheating in the next cycle. Hoses of all types fail rapidly in such an application and PTFE lined hoses are no exception.

Please contact Aflex Hose for further information if these conditions apply.

Connecting Assemblies for Use in Applications

The lengths of hose assemblies and their configuration in use when connected into the application must always be in accordance with the Hose Configuration information at the end of this product literature.

When being connected for use in applications, the end fittings on hose assemblies must be connected to correct mating parts in the correct way, using the correct tools, spanners, clamps, nuts and bolts etc. The connections must be sufficiently tightened to ensure that the joint is leak free but not be over tightened as this can damage the sealing surfaces, especially with PTFE lined and flared end fittings.

In applications involving the transfer through the hose of expensive or dangerous fluids or gases, the hoses and connections must be pressure tested in situ before being put in to service. This should be done with some harmless media to 1½ times the maximum working pressure of the hose assembly, as stated in the product literature.

If in doubt please contact Aflex Hose for advice.

Special Applications

Aflex Hose PTFE lined hose products are not rated as suitable for use in the following, special applications:

All Radioactive Applications involving high energy radiation, including Gamma radiation (degrades PTFE)

All Medical Implantation Applications.

All Aerospace Applications.

Silicone-Free Application Requirements

Some applications, particularly paint manufacturing plants, and other specialised applications require that hoses do not include any silicone containing materials in their manufacture (which is possible), or sometimes that hoses are 100% Silicone Free (which may not be possible). Customers or Distributors must identify and define any such requirements in writing on all enquiries/orders.

Corroflon and Quality Assurance, Certification and Approvals, and Hose Testing

BS EN ISO 9001:2008

Aflex products are all manufactured in accordance with BS EN ISO 9001: 2008 Quality Management Systems independently assessed and registered by National Quality Assurance Limited (NQA).

TS16949

Aflex Hose Ltd manufactures PTFE flexible hose for the automotive industry in accordance with TS16949 and is assessed and certified by National Quality Assurance Limited (NQA).

USP Class VI and ISO 10993-5, 6, 10 & 11 GUIDELINES

Natural and Antistatic PTFE Hose Liners, Platinum Cured Silicone Rubber Covers (White and Clear) and EPDM Rubber Cover (Blue) have been independently tested in accordance with USP protocols and are found to conform to the requirements of USP Class VI Chapter <88>.

Natural and Antistatic PTFE Hose Liners and Platinum Cured Silicone Rubber Covers (White and Clear) have also been tested in accordance with USP protocols and are found to conform to the requirements of USP Class VI <87>, the L929 MEM Elution Test and are considered non-cytotoxic.

FDA

The Materials used to manufacture the natural PTFE Tube liner conforms to FDA 21 CFR 177.1550, and the antistatic PTFE liner conforms to FDA 21 CFR 178.3297.

3-A Sanitary Standards

The PTFE used in the liner is manufactured solely from materials which meet the requirements of the 3-A Sanitary Standards.

Pharmaceutical Manufacturers Approvals

Most of the major pharmaceutical manufacturing companies in the world have audited and/or approved Aflex Hose as a Hose Supplier.

BPSA Leachables and Extractables Testing

Aflex Hose Natural and Antistatic PTFE Hose Liner Tube has been independently tested in accordance with BPSA recommendations, and found to be satisfactory.

Copies of the Test Report are available for specific assessments to be made.

CE Marking (Europe only)

Aflex has been assessed by a notified body and found to comply with the Pressure Equipment Directive 97/23/EC (European Community) Conformity Assessment Module D1, approved to CE Mark applicable hose products, accompanied by a Hose Usage Data Sheet, and a Declaration of Conformity.

Attestations of Conformity to ATEX Directive 94/9/EC (Potentially Explosive Atmospheres)

Available for hose assemblies for components used in Gas Zones 1 & 2 and Dust Zones 21 & 22, when applicable.

Material Certification to EN10204

Available for all the hose or hose assembly components.

Certificates of Conformity to BS EN ISO/IEC 17050

Are available for all products.

Hose Testing

Each assembly is pressure tested to 1.5 times maximum working pressure before despatch, and pressure test certificates can be supplied.

Fire Resistance to BS5173 Section 103.13 Part 6.2 and 6.3

RC Grade Corroflon hose assemblies are "Fire Resistant". If DRC-300 is added at both ends, the assemblies are upgraded to "Fire Proof".

How to Order Corroflon Hose Assemblies

How to Order

The quantity, hose size, liner, braid, cover, protection system, length and fittings must be selected and specified in full.

EITHER by a full, written description. The hose grade can be specified by the code initials e.g. "Corroflon AS, SS, RC, DRC-300" defines an antistatic PTFE lined hose with an EPDM rubber cover over a SS braid, with a double rubber cover at both ends.

The quantity, length and fittings can then be written in - e.g. "4 off x 1" bore Corroflon, AS, SS, RC, DRC-300 hose x 3.00 metres long (10ft). Both ends non-lined ANSI 150# S/S Flanges".

OR by Part Numbers, as defined on page 11.

Any special requirements relating to the hose construction, or information required on Tags, or Certificates, or special testing of requirements, must be specified in full on the enquiry or purchase order.

Selecting the Hose Grade

PTFE Liners include, Standard (GP) or Special Purpose (SP), both available either in natural white PTFE or in black, Antistatic PTFE (AS). There are four types of braid, Grade 304 stainless steel (SS) polypropylene (PB), Hastelloy (HB), PVDF or Kynar (KYB). These are described on pages 12 & 13. Rubber covering and other external protection systems are also available, described on page 14.

A hose grade is specified by using the abbreviations given. For example, Bioflex AS,PB would describe a hose with an anti-static PTFE liner and a polypropylene braid.

Note: Most of the sizes of hose and fittings listed in this brochure are available as ex-stock items and are priced accordingly. However, when certain items have not been purchased in the last 12 months, they are no longer held in stock, and are only available to Special Order.

Aflex Hose will advise accordingly when enquiries are placed for these items.

Selecting the Hose Length (see also pages 33 - 35)

Corroflon hose assemblies are made up to the specific lengths required. The hose length is taken as the length from the sealing face at one end of the hose to the same at the other end. The length tolerance is normally +10% -0% for lengths more than 1 mtr, and +5%-0% for lengths up to 1 mtr. Closer tolerances are available to special order.

Corroflon Hose Assembly Length Limitations									
Nominal Size of Hose		*Minimum Hose Assembly Length						Maximum Hose Assembly Length	
		Used Straight		Minimum at MBR					
		All Types		TO, SS, PB, KYB		RC			
in	mm	in	mm	in	mm	in	mm	ft	mtrs
1/2	15	3	75	2.36	60	3.54	90	91	28
3/4	20	3	75	3.19	81	4.72	120	98	30
1	25	3	75	4.33	110	6.50	165	131	40
1 1/4	32	3	75	5.08	129	7.64	194	98	30
1 1/2	40	3	75	6.22	158	9.29	236	82	25
2	50	3	75	8.66	220	12.99	330	60	18
2 1/2	65	4	100	11.02	280	16.54	420	43	13
3	80	4	100	14.25	362	21.34	542	32	10
4	100	12	300	18.58	472	27.83	707	16	5
6	150	12	300	37.13	943	55.67	1414	14	4

* Listed minimum lengths are for the Corroflon Hose only, and **DO NOT INCLUDE THE LENGTHS OF THE FITTINGS AT EACH END.** These must be found from the end fitting pages and added to calculate the minimum length of the hose assembly.

Used straight with fittings in line.

Only minimal vibration permitted.

Selecting the End Fittings

Corroflon is available with a range of 'standard' end fittings (described on pages 15-32), both integral PTFE lined and non-lined

Stainless Steel End Fitting Materials

Non-Lined Spigots - are all made from Grade 316L SS

PTFE Lined Spigots - are all made from Grade 316L or Grade 316C SS

Cam and Groove Female Fittings - are made from Grade 316C SS (Body) and 316L SS (Spigot)

Swivelling Nuts and Flanges - are all made from Grade 304 SS

Ferrules - most ferrules are made from Grade 304 SS, except some are made from Grade 316L SS - consult Aflex Hose if necessary.

The equivalent specification for the different Grades of Stainless Steel are listed below:

Grade	BS - British Standard	AISI - American Standard or C = Casting Grade	EN - European Norm
316L SS	BS 316 S11	AISI 316 L	EN 1.4404
316C SS	BS 316 C16	CF8M	EN 1.4408
304 SS	BS 304 S15	AISI 304	EN 1.4301

Conditions of Sale

Corroflon hose and hose assemblies are only supplied on the basis that the customer has read and accepted the Conditions of Sale as given at the end of this brochure and on the Aflex Hose website.

Corroflon Hose Assembly Part Number System

If required, Corroflon Hose Assembly can be defined by an individual Part Number, made up of ⑦ entries as below:

①	Hose Size	Size Part No.
	1/2"	08
	3/4"	12
	1"	16
	1 1/4"	20
	1 1/2"	24
	2"	32
	2 1/2"	40
	3"	48
	4"	64
	6"	96

②	Hose Type	Type Part No.
	Corroflon GP (Natural PTFE Liner)	CFLN/GP
	Corroflon AS (Antistatic PTFE Liner)	CFLN/AS

③		Braid and Cover
	Tube Only	TO
	Stainless Steel Braid	SS
	Polypropylene Braid	PB
	Hastelloy Braid	HB
	Kynar (PVDF) Braid	KYB
	Black EPDM Rubber Cover (on SS)	RC
	Transparent Silicone Rubber (on SS)	SI
	Red Fireproof EPDM Rubber (on SS)	FP

④		External Protection Systems
	No External Protection System	OO
	SS Wire Protection Coil	PC
	Rubber Anti-Scuff Rings	SR
	'Safeguard' HDPE Spiral Wrap	SG

⑤	Length
	The overall hose length between the sealing faces at each end is given as the Length Part No, either in decimal Metres followed by "m" or Inches followed by "in".

⑥ & ⑦	Assembled End Fitting Description *All Components in Stainless Steel	End Fitting Part No.
	JIC Female	02
	Fixed Male Pipe, NPT Thread	03
	Fixed Male Pipe, BSPT Thread	03/B
	Fixed Female Pipe, NPT Thread	06
	JIC-to-NPT Male Union	08
	JIC-to-Female Male Union	08F
	Straight Sanitary Tri Clamp, 1.984" Diameter 0.870" Exit Diameter (Standard) 1.370" Exit Diameter (Step-Up)	10 10/S
	Straight Mini Sanitary Tri Clamp, 0.984" Diameter 0.370" Exit Diameter (Standard) 0.625" Exit Diameter (Step-Up)	11 11/S
	*ANSI 150# Swivelling Flange Non-Lined	12
	DIN PN 10/16 Swivelling Flange Non-Lined	12/PN
	*ANSI 150# Swivelling Flange, PTFE Lined	12L
	DIN PN 10/16 Swivelling Flange, PTFE-Lined	12L/PN
	Cam and Groove, Locking Arm Swivelling Female, Non-Lined	16
	Cam and Groove Locking Arm Swivelling Female, PTFE Lined	16L
	Cam and Groove Male, Non-Lined	17
	Cam and Groove Male, PTFE Lined	17L
	DIN 11851 Female, PTFE Lined	23L
	DIN 18851 Male, PTFE Lined	24L
	SMS Female, PTFE Lined	26L
	RJT Female, Non-Lined	27
	BSPP Cone Seat Female	33
	BSP Lug Nut Female	34

*For flange only, Carbon Steel Zinc Plated, add "/ZP" or Epoxy coated add "/EC"

Notes: ELBOWS - Elbow Fittings for all types are indicated by adding "/90" for 90° elbows.

TRICLAMPS: For "Hot Formed" PTFE Lined Triclamps add "/HF"

Example: a 3/4" bore Corroflon GP, RC Hose Assembly with an Antistatic PTFE Liner and an outer Safeguard sleeve.

End (1) - a 3/4" ANSI 150# Swivel Flange, PTFE Lined

End (2) - a Cam and Groove Swivelling Female, PTFE Lined

Length - 4ft 6 inches

Hose Assembly Part No. = 12 - CFLN/AS - RC - SG - 54in - 12L - 16L

① ② ③ ④ ⑤ ⑥ ⑦

ADDITIONAL REQUIREMENTS

Any additional requirements which are not included in the Part Number must be written out in full in the Order, including any special labelling or colour coding

* **Note** - if one of the rubber end protection systems is required, for one or both ends, please define the requirement in writing in addition to the Part Number.

Corroflon Hose Liners

GP - General Purpose Liner



Purpose

Corroflon GP, SS is the general purpose grade of hose and has been carefully designed to satisfy the widest range of application requirements.

Design & Approvals

The hose liner is manufactured from hose quality grade PTFE conforming to FDA requirements 21 CFR 177.1550 extruded into tube and helically convoluted. It also includes a heavy gauge Grade 304 stainless steel reinforcing wire helically wound into the external root of the convolutions to strengthen the convoluted shape. The braid is high tensile grade 304 stainless steel wire braid to give maximum protection to the hose against internal pressure and external abrasion.

Corroflon GP hose liner tube also conforms to USP Class VI at normal temperatures and at 121°C (250°F), see page 9.

SP - Special Purpose Liner



Purpose

For applications requiring a higher temperature/pressure rating, greater flexibility and improved kink and crush resistance. Also for applications requiring full vacuum resistance for hose sizes larger than 2".

Design

The convolutions are closer together, yielding greater radial strength to the hose design.

Specifications

As for Corroflon GP, except that the maximum working pressure for wire braided grades is increased by 25%, the weight per metre is increased by 30%, the actual through bore is reduced by 1/8" (3mm), the maximum continuous length is reduced by 50%, the minimum bend radius is reduced by 25% and the angle of cleanability is <80°.

Available as SP (Natural) and SP, AS (Antistatic) Grades.

AS - Antistatic PTFE Liner



Purpose

Corroflon AS grade is an essential requirement in applications where there is the risk of an electrostatic charge build-up on the inside surface of the PTFE tube which may then discharge through the tube wall. Media passing through which create such a risk are fluids which have a Conductance of less than 10⁻⁸ S/m (Siemens per Metre), or 10⁴ pS/m such as fuels, solvents, freons, some WFI (ultra-pure "Water for Injection") and non-polar organics which are being transferred at a medium to high flow velocity.

All twin or multi phase media, and any non-mixing media, such as powder in air, or water droplets in steam, in gases or in oil, also colloidal fluids constitute a particular hazard for static charge generation, and always require grade AS.

A typical example involves cleaning systems which create a twin phase mixture passing through the hose at high velocity, such as WFI water purged out with air or nitrogen.

If in doubt, consult Aflex Hose.

Design & Approvals

Corroflon AS grade has an anti-static PTFE liner manufactured from FDA 21 CFR 177.1550 approved PTFE, and less than 2.5% of "high purity" Carbon Black material to FDA requirement 21 CFR 178.3297 and European Commission Directive 2007/19/EC. The carbon is encapsulated by the PTFE, and in normal, non-abrasive applications will not come loose to contaminate any fluid passing through. (This has been confirmed by Extractables and Leachables Tests in accordance with BPSA recommendations).

Corroflon AS hose liner tube also conforms to USP Class VI at normal temperatures and at 121°C (250°F), see page 9.

Antistatic Hose Assemblies

When "AS" (Antistatic) grade hose is specified, then the hose or hose assembly supplied will be tested in accordance with EN ISO 8031 and meet the Antistatic requirements of EN ISO 8031 Annex A. This requires, for an antistatic liner or antistatic cover, that the resistance between an appropriately placed foam electrode and a metallic end fitting will be between 10³ to 10⁸ ohms per assembly. For hose assemblies which meet these requirements an appropriate Grade "Ω" marking can be applied in accordance with EN ISO 8031 Annex A if requested.

NOTE: When in service, at least one end fitting must be connected to earth, to permit dissipation of the static charge from the end fitting.

Corroflon Hose Braids

SS - Stainless Steel Braid



Purpose

Stainless Steel braided hose is the general purpose product, and can be used in applications involving high temperatures and working pressures. High tensile AISI 304 stainless steel wire is used, to give maximum pressure resistance and external protection to the hose.

PB - Polypropylene Braid



Purpose

Polypropylene braided hose is often preferred to SS in applications involving frequent handling and movement of the hose, and where temperatures are within the range -30°C to +100°C (-22°F to +212°F). PB braid is lighter in weight, and any broken strands will not cut the operator's hands. In addition, PB braid is not prone to "chloride stress corrosion", and has generally good chemical resistance.

NOTE: Prolonged exposure to sunlight eventually results in UV degradation of PB braid.

KYB - Kynar Braid (Polyvinylidene Fluoride Monofilament)



Purpose

Kynar Braid is used in the same application as Hastelloy Braid, but only in applications where the reduced pressure ratings of KYB as listed are acceptable. A Safeguard Sleeve is always recommended. Monel or Hastelloy wire should be used.

Full details about the applications should be given to Aflex Hose for evaluation and recommendations.

TO - Tube Only (no braid)

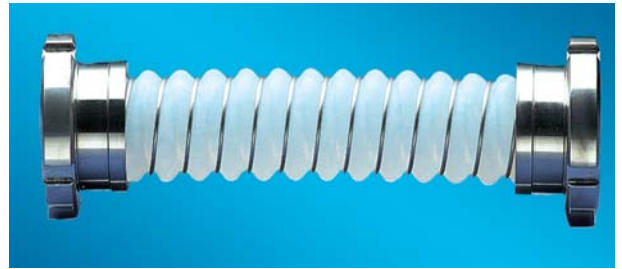

Purpose

TO grade hose (available in both GP and AS) is a lightweight hose, used in applications where working pressures are low and where there is no need for the physical protection offered by an external braid.

HB - Hastelloy Braid (C276 grade)



Purpose

Hastelloy Wire Braid is used instead of SS where severe chemical corrosion conditions exist around the outside of the hose. The most usual way in which this can happen is when Chlorine, Bromine, Hydrogen Fluoride, Hydrogen Chloride or Phosgene are being transferred. Diffusion of trace quantities of such fluids or gases through the PTFE liner can lead to atmospherically wetted halogen chemicals attacking the braid material, in which case the Hastelloy Braid would be resistant up to 60°C (140°F) maximum. This should only be used, however, in conjunction with a Monel or Hastelloy Helix Wire.

Full details about the applications should be given to Aflex Hose for evaluation and recommendations.

Specifications

Same as for SS on Page 7, except the Burst Pressures and the Maximum Working Pressures are both reduced to 80% of the SS pressures listed.

Also, the sizes range is restricted, from 1/2" up to 2" bore only.

SPECIAL NOTE:

EC - Electrical Continuity (Also known as "Electrically Bonded")

The requirements for this are specified in the German Document BRG 132 and EN ISO 8031 Annex A, when tested in accordance with EN ISO 8031, which requires that the resistance between end fittings shall be <math><10^2</math> ohms per assembly. For hose assemblies which meet this requirement a Grade "M" marking can be applied in accordance with EN ISO 8031 Annex A if requested.

Corroflon Rubber Covers

RC - EPDM Rubber Covered - Antistatic and Fire Proof Black Rubber Cover

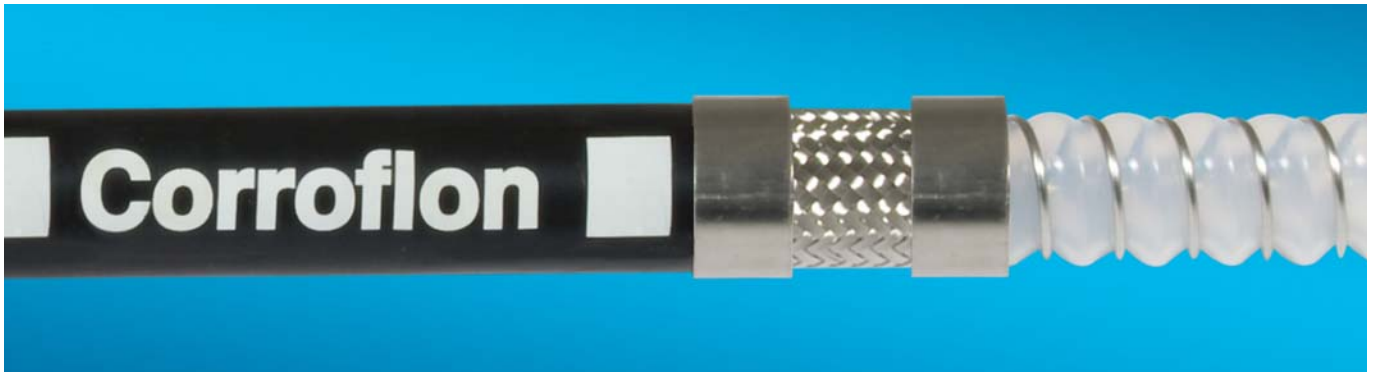

Purpose

For the most rugged applications where the hose may be subjected to rough treatment and severe external abrasion. Also for hygienic applications, where the external cleanability of the hose is of prime importance and in applications where the hose is required to be Fire Proof, or to have an Antistatic cover.

Design

An SS braided hose has a black, antistatic EPDM external rubber cover extruded directly onto the braid to produce a super-smooth external surface finish. Sizes above 2" bore are hand-wrapped, not extruded.

EPDM has excellent chemical resistance, and the hose has a temperature range from -40°C, -40°F up to +140°C, +284°F .

Fire Proof

As well as providing an Antistatic cover, Corroflon RC hose is also Fire Proof in accordance with Specification BS5173 Section 103.13 part 6.2 (Fireproof). This specification calls for an 1100°C (2012°F) flame to be applied to the hose at minimum bend radius, maximum operating pressure (water), and one end fitting under vibration. The hose must withstand at least 15 minutes without leakage.

Hose assemblies are Fire Resistant, but can be rendered Fire Proof by the addition of DRC-300 at both ends - see below.

Corroflon RC hose meets the requirements of German Safety Regulation TRBF 131/2.

SI - Silicone Rubber Cover



Purpose

As for RC hose, but where the hose may be required to withstand temperatures from -73°C, -100°F up to +204°C, +400°F. SI grade hose is semi-transparent, allowing visual monitoring of the braid.

Design

An SS braided hose assembly has an external smooth finish, platinum cured silicone rubber cover extruded (>50 metres) or hand-wrapped (<50 metres), and vulcanised directly onto the braid.

Specifications

The Silicone rubber cover has been tested and conforms to the requirements of USP Class VI, see page 9.

RC-300 - Rubber Covered 300mm at End



Purpose

In applications where excessive flexing of the hose at the end fitting occurs, it is sometimes necessary to 'stiffen' the hose in this area, to prevent kinking.

Design

A layer of rubber is hand-wrapped and vulcanised directly to the ferrule, and 300mm (12 inch) along the hose from the fitting. This can be done either on an SS braided hose (RC-300 or SI-300) or on a rubber covered hose as a 300mm (12 inch) long double layer of rubber at the end (DRC-300 or DSI-300).

Corroflon External Protection Systems

SG - Safeguard Protection Sleeve



Purpose

To protect the hose against external abrasion and mechanical damage. For use in applications where maximum external protection is required with minimum extra hose weight. Particularly useful with PB or KYB hose, where a rubber cover is not an option.

Design

A lightweight black, HDPE (High Density Poly Ethylene) strip spirally wound around the outside of the hose over its whole length, secured to each end fitting by crimping under a SS ferrule.

Limitations

Safeguard is applicable to all hose types and all hose sizes from 1/2" up to 4".

Safeguard is limited to use within a temperature range from -40°C (-40°F) up to +100°C (212°F). Internal fluid temperatures up to 120°C (250°F) are acceptable, when external temperatures are ambient.

The minimum hose assembly length must be doubled, if Safeguard is being used and the maximum assembly lengths for all sizes are capped at 20 metres (65 feet).

The other hose usage limitation specifications are not altered by the addition of Safeguard.

SR - Scuff Rings



Purpose

For medium duty applications where the hose requires some protection against abrasion when dragged over the ground, but where a full rubber cover would be too heavy and cumbersome. Also for PB and KYB braided hose, which cannot be Rubber Covered.

Design

Specially moulded abrasion resistant rubber scuff rings are placed every half metre along the hose.

Limitations

Available for hose sizes 1" (25mm) to 2" (50mm) only. The operating temperature should not exceed 140°C (284°F) (internal).

PC - Protection Coil



Purpose

For applications where the hose requires protection against abrasion when dragged over the ground, but where any rubber reinforcement is not permissible due to temperature, chemicals etc.

Design

A stainless steel wire helix is wound onto the braid and welded to the ferrules at each end.

Limitations

Available for all sizes and grades of hose, including rubber covered.

The maximum assembly lengths for all sizes are capped at 20 metres (65 feet).

Specifications

As for the relevant hose grade.

Corroflon Non Lined Swivel Flange Fittings

Flange Specification

- ANSI B16.5 (also ASME B16.5) Class 150# and 300#
- *DIN PN10/16/40 up to 2" size, PN10/16 from 2 1/2" up to 6" size
- JIS 10K
- Other Pressure Ratings and Flange Specifications are also available

*The dimensions for flanges to the different pressure ratings are identical, so they are inter-changeable.

Maximum Pressure Ratings for Flange Fittings

- ANSI 150# = 16 Bar (230 psi), ANSI 300# = 32 Bar (460 psi)
- DIN PN10 = 10 Bar (145 psi), DIN PN16 = 16 Bar (230 psi), DIN PN40 = 40 Bar (580psi)

End Fitting Materials

- Flanges in Grade 304 SS
- Flange Retainers in Grade 316L SS
- Ferrules, most in Grade 304 SS, some sizes in Grade 316 SS



Alternative Options for Flange Component only:

- Zinc Plated Carbon Steel
- Grade 316 Stainless Steel

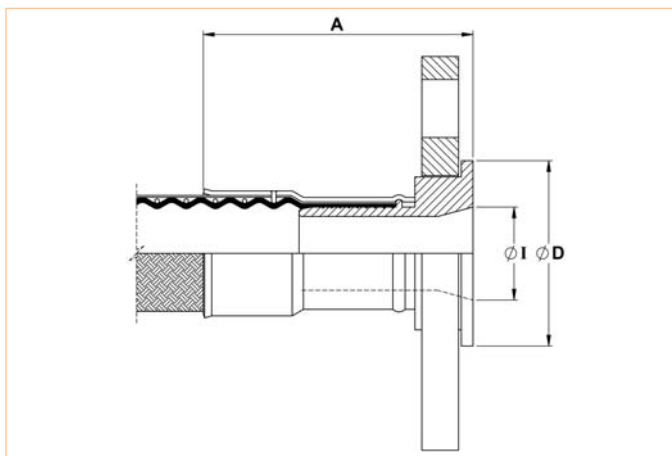

The above drawing relates to sizes 1", 1 1/2", 2"

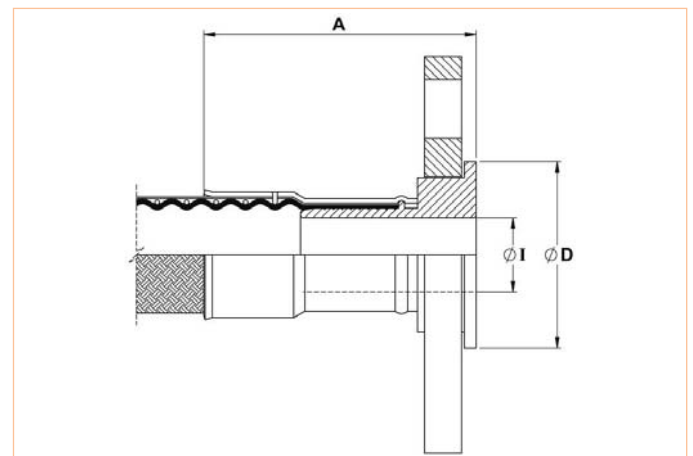

The above drawing relates to all other sizes

Nominal Hose Size		*Fitting Length PN A		Flared Diameter D PN10/16		Fitting Inside Diameter I		Weight of Fitting	
in	mm	in	mm	in	mm	in	mm	Kg	Lbs
1/2	13	2.20	56	1.77	45	0.39	10	0.76	1.69
3/4	20	3.11	79	2.28	58	0.63	16	1.06	2.35
1	25	3.46	88	2.68	68	1.12	28.5	1.36	3.00
1 1/4	32	3.98	101	3.07	78	1.02	26	1.72	3.79
1 1/2	40	4.69	119	3.46	88	1.69	43.10	2.49	5.50
2	50	4.69	119	4.02	102	2.15	54.5	3.57	7.87
2 1/2	65	4.88	124	4.80	122	2.24	57	4.20	9.26
3	80	5.16	131	5.43	138	2.64	67	5.68	12.52
4	100	5.51	140	6.22	158	3.50	89	8.42	18.56
6	150	4.76	121	8.35	212	5.51	140	12.30	27.12

*Fitting Lengths listed are for Corroflon braided only hose grades (SS, PB, HB, KYB). Approximately 33% longer lengths apply to the rubber covered hose grades (RC, SI, FP).

Nominal Hose Size		*Fitting Length ASA A		Flared Diameter D ASA150		Fitting Inside Diameter I		Weight of Fitting	
in	mm	in	mm	in	mm	in	mm	Kg	Lbs
1/2	13	2.13	54	1.37	34.9	0.39	10	0.76	1.69
3/4	20	2.99	76	1.69	42.9	0.63	16	1.06	2.35
1	25	2.95	75	2.00	50.8	0.79	20.24	1.36	3.00
1 1/4	32	3.78	96	2.50	63.5	1.02	26	1.72	3.79
1 1/2	40	4.25	108	2.87	73.0	1.25	31.75	2.49	5.50
2	50	4.41	112	3.63	92.1	1.75	44.45	3.57	7.87
2 1/2	65	4.65	118	4.12	104.5	2.24	57	4.20	9.26
3	80	4.88	124	5.00	127.0	2.64	67	5.68	12.52
4	100	5.51	140	6.19	157.2	3.50	89	8.42	18.56
6	150	4.76	121	8.50	215.9	5.51	140	12.30	27.12

Corroflon Integral PTFE Lined Flange Fittings & "Step-Up" Design

Flange Specification

- ANSI B16.5 (also ASME B16.5) Class 150# and 300#
- *DIN PN10/16/40 up to 2" size, PN10/16 from 2 1/2" up to 6" size
- JIS 10K
- Other Pressure Ratings and Flange Specifications are also available

*The dimensions for flanges to the different pressure ratings are identified, so they are inter-changeable.

Maximum Pressure Ratings for Flange Fittings

- ANSI 150# = 16 Bar (230 psi), ANSI 300# = 32 Bar (460 psi)
- DIN PN10 = 10 Bar (145 psi)
- DIN PN16 = 16 Bar (230 psi), DIN PN40 = 40 Bar (580psi)

End Fitting Materials

- Flanges in Grade 304 SS
 - Flange Retainers in Grade 316L SS
 - Ferrules, most in Grade 304 SS, some sizes in Grade 316L SS
- Alternative options for Flange component only:
- Zinc Plated Carbon Steel
 - Grade 316 Stainless Steel

90° Elbow Flange Fittings (see page 29)

90° Elbow Integral PTFE lined Flange Fittings are available for 1", 1 1/2" & 2".

Integral PTFE Lined Swivel Flange Fittings

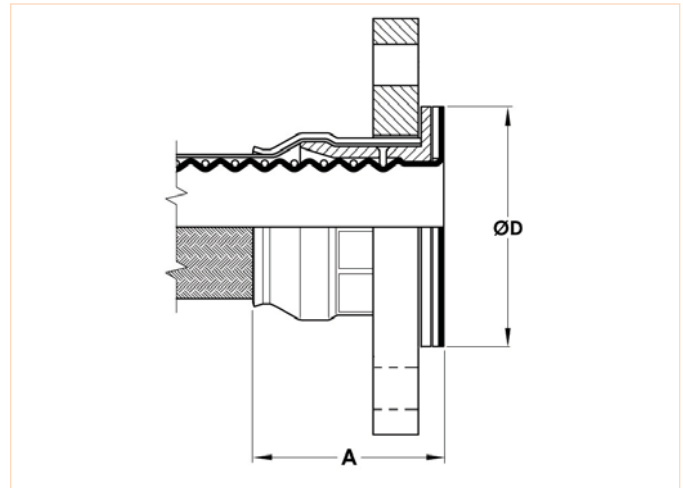

Nominal Size I - Flange & Hose		*Fitting Length ASA A		*Fitting Length PN A		Flared Diameter D		Recommended Bolt Tightening Torques		Weight of Fitting	
in	mm	in	mm	in	mm	ASA150 mm	PN10/16 mm	ft.lbs	Nm	kg	Lbs
1/2	15	2.09	53	2.09	53	32.0	32.0	8	10.79	0.54	1.19
3/4	20	2.28	58	2.34	59.5	43.0	50.0	8	10.79	0.88	1.94
1	25	2.28	58	2.36	60	50.8	63.5	10	13.73	0.96	2.11
1 1/4	32	2.48	63	2.52	64	63.0	78.0	12	16.67	1.36	2.99
1 1/2	40	2.40	61	2.50	63.5	73.0	88.0	15	20.59	1.75	3.85
2	50	2.52	64	2.62	66.5	92.0	102.0	25	34.32	2.70	5.94
2 1/2	65	3.11	79	3.19	81	105.0	122.0	30	41.18	4.00	8.80
3	80	3.11	79	3.11	79	127.0	127.0	40	53.94	5.00	11.00
4	100	5.20	132	5.20	132	158.0	158.0	40	53.94	7.00	15.40
6	150	3.66	93	3.66	93	213.0	213.0	50	67.67	13.00	29.00

*Fitting Lengths listed are for Corroflon braided only hose grades (SS, PB, HB, KYB). Approximately 33% longer lengths apply to the rubber covered hose grades (RC, SI, FP).

*"Step-Up" PTFE Lined Flange Fitting Design for Corroflon Hose

Adapting for Different Flange Sizes

To fit larger than nominal flange sizes

It may be necessary to fit a larger than nominal flange size to the hose - for example, 3" flange fitted to one end of a 2" hose - in which case it may also be necessary to increase the diameter of the sealing face to the correct size for the larger flange. This can be achieved by means of a flange adaptor as shown.

To fit smaller than nominal flange sizes

Within limits, it is also possible to make up an assembly with a flange one size smaller than the nominal size. The smaller flange is bored and fitted to the larger hose and, if necessary, the flared diameter is reduced to suit.

Consult the supplier if a different flange size is required.

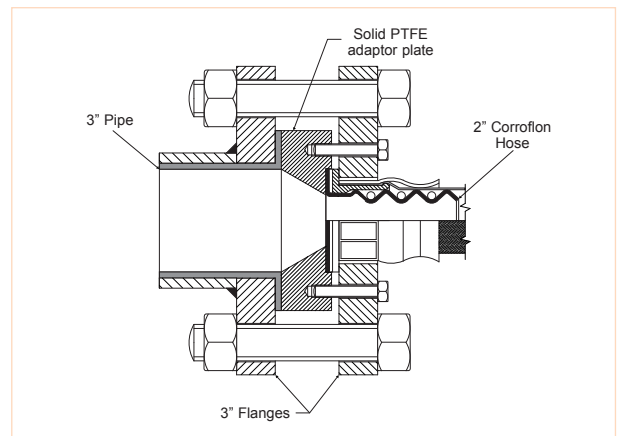

Corroflon Female Cam & Groove Fittings PTFE Lined (Fixed) and Non-Lined (Swivel), Locking Arms

End Fitting Specification

- Generally in accordance with A-A-59326 (replaces MIL-C-27487) and EN14420-1 (replaces DIN 2828), and all are fully interchangeable.

Temperature and Pressure Ratings

- When used with a Buna N Gasket all sizes up to 16 Bar (230 psi) and up to a maximum temperature of 65°C (149°F).
- When used with FEP, Fluoro Rubber or other encapsulated gaskets all sizes up to 10 Bar (145 psi) and up to a maximum temperature of 204°C (400°F).

End Fitting Materials

- Spigot in Grade 316L SS
- Body in Grade 316C SS
- Ferrules, most in Grade 304 SS, some sizes in Grade 316L SS
- Standard Gasket is Buna N (Nitrile) Rubber.
- FEP encapsulated Silicone Rubber Gaskets also available.

90° Elbow Cam & Groove Fittings (LINED ONLY)

- 90° Elbow Integral PTFE lined Cam & Groove Fittings are available for sizes 1", 1 1/2" and 2" - see page 29.

Swivelling, Locking Arm Female Cam and Groove Fittings - Non Lined

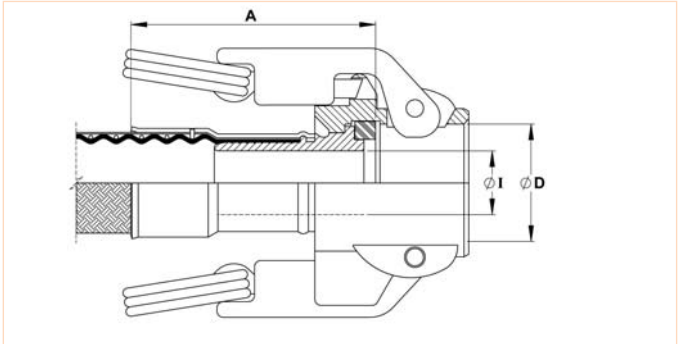
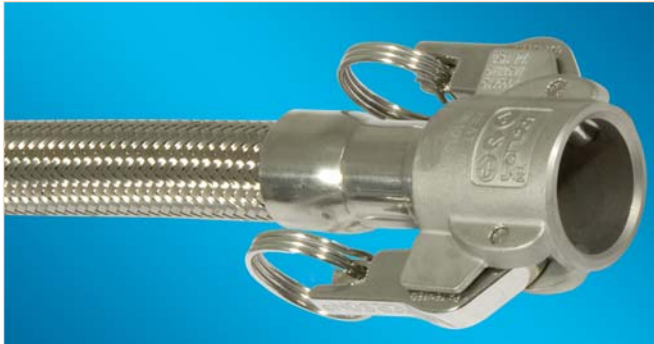

Nominal Hose Size		*Fitting Length A		Cam Sleeve Inside Diameter D		Fitting Inside Diameter I		Weight of Fitting	
in	mm	in	mm	in	mm	in	mm	Kg	Lbs
3/4	19.1	3.11	79	1.26	32	0.63	15.9	0.40	0.88
1	25.4	3.07	78	1.46	37	0.75	19.1	0.51	1.12
1 1/2	38.1	4.13	105	2.13	54	1.25	31.8	0.88	1.94
2	50.8	4.25	108	2.52	64	1.75	44.5	1.15	2.53
2 1/2	63.5	4.49	114	3.03	77	2.25	57.2	1.41	3.10
3	76.2	4.61	117	3.62	92	2.63	66.7	1.89	4.17

*Fitting Lengths listed are for Corroflon braided only hose grades (SS, PB, HB, KYB). Approximately 33% longer lengths apply to the rubber covered hose grades (RC, SI, FP).

Fixed, Locking Arm Female Cam and Groove Fitting - Integral PTFE Lined

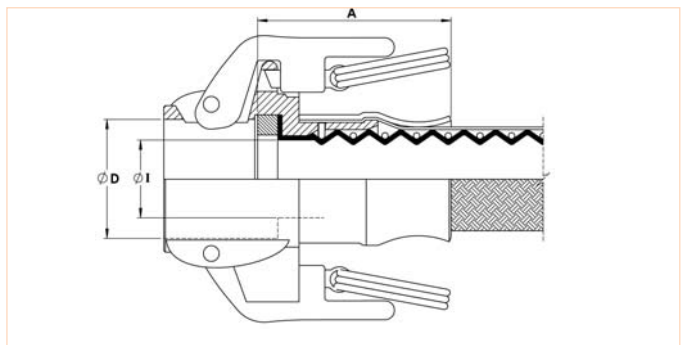

Nominal Hose Size		*Fitting Length A		Cam Sleeve Inside Diameter D		Fitting Inside Diameter I		Weight of Fitting	
in	mm	in	mm	in	mm	in	mm	Kg	Lbs
3/4	19.1	2.48	63	1.26	32	0.70	17.8	0.39	0.86
1	25.4	2.40	61	1.46	37	0.95	24.1	0.50	1.10
1 1/2	38.1	2.56	65	2.13	54	1.44	36.7	0.86	1.89
2	50.8	2.56	65	2.52	64	1.94	49.3	1.10	2.42

Notes: For Integral PTFE Lined Fittings Only

FEP Gaskets require higher clamping forces to flatten the Seal and make the joint. This is made easier by "pre-setting" these gaskets by clamping Polypropylene Cam Male Inserts to the assembled fittings, which must then be kept in place during storage, until use.

Any Customer's Own "Special" Gaskets must be pre-supplied to Aflex for special assembly and testing of hose assemblies, to ensure suitability.

*Fitting Lengths listed are for Corroflon braided only hose grades (SS, PB, HB, KYB). Approximately 33% longer lengths apply to the rubber covered hose grades (RC, SI, FP).

Corroflon Male Cam & Groove Fittings, PTFE Lined & Non-Lined and Flange Adaptors, PTFE Lined

PTFE Lined or Non-Lined Male Cam and Groove Fittings

End Fitting Specification

- Generally in accordance with A-A-59326 (replaces MIL-C-27487) and EN14420-1 (replaces DIN 2828), and all are fully interchangeable.

Temperature and Pressure Ratings

- Temperature and pressure determined by the type of gasket in the Female connecting component.

End Fitting Materials

- Fittings in Grade 316L SS
- Ferrules, most in Grade 304 SS, some sizes in Grade 316L SS
- Adaptor Flange Only in Grade 304 SS

Integral PTFE Lined Cam & Groove Male Fitting

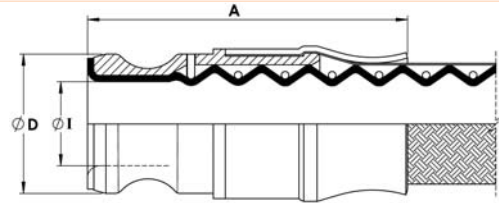

Non-Lined Cam & Groove Male Fitting

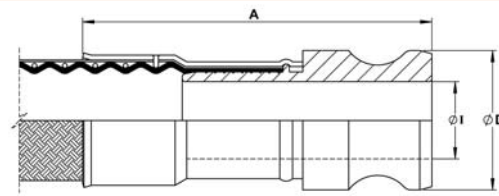

Non-Lined Cam & Groove Male



Nominal Hose Size		ØD		Fitting Length A		Non-Lined Inside Diameter I		Lined Inside Diameter B		Weight of Fitting	
in	mm	in	mm	in	mm	in	mm	in	mm	Kg	Lbs
3/4	19.1	1.26	32	3.38	86	0.63	15.88	0.70	17.78	0.40	0.88
1	25.4	1.46	37	3.66	93	0.80	20.24	0.88	22.35	0.49	1.08
1 1/2	38.1	2.13	54.0	5.00	127	1.25	31.75	1.12	28.50	0.81	1.78
2	50.8	2.52	64	5.67	144	1.75	44.45	1.77	44.96	1.05	2.31

*Fitting Lengths listed are for Corroflon braided only hose grades (SS, PB, HB, KYB). Approximately 33% longer lengths apply to the rubber covered hose grades (RC, SI, FP).

PTFE LINED MALE CAM and GROOVE X FLANGE ADAPTORS

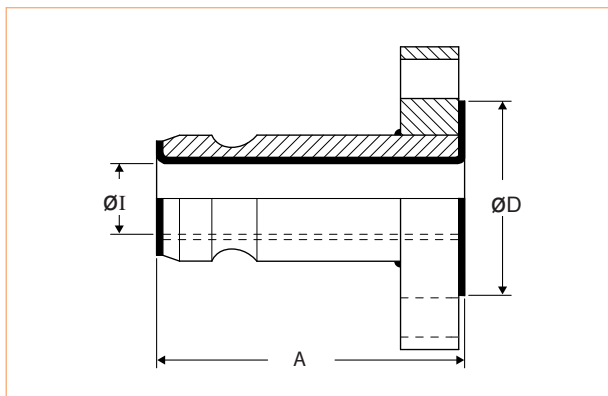

Cam Action Adaptor Size		Flange Size & Specification	ØD		A		I		Weight of Fitting	
in	mm		in	mm	in	mm	in	mm	Kg	Lbs
1	25	1" ANSI/1507	2.00	50	4 1/8	105	0.84	21	1.246	2.75
1	25	DN25/PN16	2.58	64	4 1/8	105	0.84	21	1.538	3.39
1 1/2	40	1 1/2" ANSI/1507	2.87	73	4 3/8	118	1.35	34	2.228	4.92
1 1/2	40	DN40/PN16	3.47	88	4 3/8	118	1.35	34	2.753	6.07
2	50	2" ANSI/1507	3.63	92	4 3/8	118	1.69	43	3.359	7.40
2	50	DN50/PN16	4.02	102	4 3/8	118	1.69	43	3.714	8.19

Note: Other Flange Specifications and Pressure Ratings are also available. Non-Lined adaptors and Female Cam and Groove X Flange Adaptors are also available, to special order.

Corroflon Mini-Sanitary and Sanitary Triclover Fittings - PTFE Lined

End Fitting Specification

- BS4825 Pt 3 (UK)
- ASME BPE-a-2007 (USA)
- DIN32676 (Europe, DN Sizes)
- ISO 1127 (Europe) (Non Standard, Specials Only)

Temperature and Pressure Ratings

- Pressures up to 16 Bar (230 psi)
- Temperatures up to 180°C (356°F)
- Higher Pressures & Temperatures possible with Special Clamps and appropriate Seals.



End Fitting Materials

- Fittings in Grade 316L SS (= BS 316 S11 = EN 1.4404)
- Ferrules, most in Grade 304 SS, some sizes in Grade 316L SS

90° Elbows

PTFE Lined 90° elbow fittings are available for some sizes and grades - see page 29.

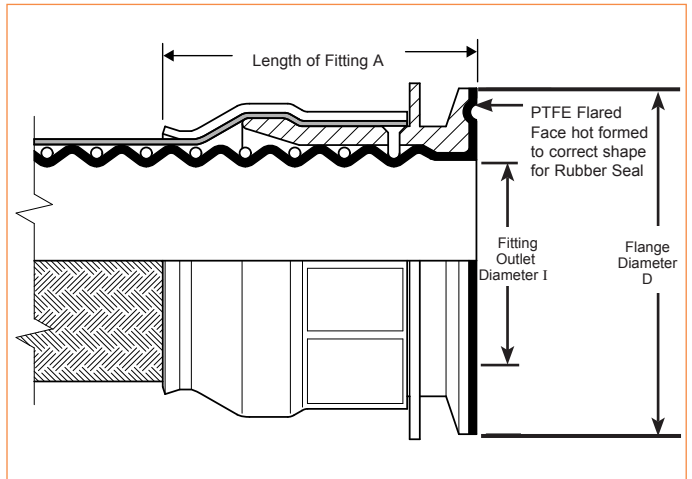

Nominal Hose Size		Nominal Pipe Size		Outlet Diameter I		Flange Diameter D	*Length of Fitting A	Weight of Fitting	
in	mm	in	mm	in	mm	in	mm	Kg	Lbs
1/2	15	1/2	12.7	3/8	9.5	25.0	50	0.075	0.17
1	25	1	25.4	7/8	22.2	50.5	60	0.226	0.50
1 1/2	40	1 1/2	38.1	1 3/8	34.9	50.5	63	0.269	0.59
2	50	2	50.8	1 7/8	47.6	64.0	66	0.407	0.90
2 1/2	65	2 1/2	63.4	2 3/8	60.3	77.5	82	0.510	1.12
3	80	3	76.1	2 7/8	73.0	91.0	82	0.593	1.30

*Fitting Lengths listed are for Corroflon braided only hose grades (SS, PB, HB, KYB). Approximately 33% longer lengths apply to the rubber covered hose grades (RC, SI, FP).

Corroflon Mini-Sanitary and Sanitary Triclover Fittings - Not PTFE Lined



End Fitting Specification

- BS4825 Pt 3 (UK)
- ASME BPE-a-2007 (USA)
- DIN32676 (Europe, DN Sizes)
- ISO 1127 (Europe) (Non Standard, Specials Only)

Temperature and Pressure Ratings

For Standard Clamp and Standard (EPDM) Gasket

- Pressures up to 16 Bar (230 psi)
- Temperatures up to 120°C (250°F)
- Higher Pressures and Temperatures with Special Clamps and Gaskets.

End Fitting Materials

- Fittings in AISI 316L = EN 1.4404 = BS 316 S11. Internal Bores all Electropolished to <math>< 15\mu\text{in Ra}</math> (<math>< 0.375\mu\text{mtr}</math>).
- Ferrules, most in Grade 304 SS, some sizes in Grade 316L SS

Outlet Diameters (Inch pipe sizes only)

The outlet diameters as listed are in accordance with BS4825. The ASME specification, however, requires these diameters to be 0.005" (0.125mm) less in each case. An Outlet Diameter tolerance of +0.000 -0.005" has therefore been applied, so that the same fitting satisfies requirements of both specifications.

MINI-SANITARY TRICLAMP (TRICLOVER) FITTINGS									
Nominal Hose Size	Nominal Pipe Size	*Fitting Length A		Flange Dia. D		Outlet Dia. I		Weight of Fitting	
		in	mm	in	mm	in	mm	Kg	Lbs
1/2"	1/2" & DN10	2.13	54	0.984	25.0	3/8	9.5	0.05	0.11
1/2"	3/4"	2.13	54	0.984	25.0	5/8	16.0	0.04	0.09
3/4"	3/4"	3.03	77	0.984	25.0	5/8	16.0	0.05	0.11

SANITARY TRICLAMPS (TRICLOVER) FITTINGS									
Nominal Hose Size	Nominal Pipe Size	*Fitting Length A		Flange Dia. D		Outlet Dia. I		Weight of Fitting	
		in	mm	in	mm	in	mm	Kg	Lbs
1/2"	1"	2.01	51	1.984	50.5	7/8	22.2	0.13	0.28
3/4"	DN15	2.96	75	1.156	34.0	5/8	16.0	0.12	0.26
3/4"	ISO (DN) 15	2.96	75	1.984	50.5	0.713	18.10	0.16	0.35
3/4"	ISO (DN) 20	2.96	75	1.984	50.5	0.934	23.7	0.15	0.33
1"	1"	3.39	86	1.984	50.5	7/8	22.2	0.25	0.54
1"	DN25	3.39	86	1.984	50.5	1	26.0	0.24	0.52
1"	ISO (DN) 25	3.39	86	1.984	50.5	1.170	29.7	0.23	0.52
1"	1 1/2"	3.39	86	1.984	50.5	1 3/8"	34.9	0.22	0.48
1 1/2"	1 1/2"	4.02	102	1.984	50.5	1 3/8"	34.9	0.27	0.59
1 1/2"	DN40	4.02	102	1.984	50.5	1 1/2"	38.0	0.25	0.56
2"	2"	4.25	108	2.516	64.0	1 7/8"	47.6	0.39	0.86
2"	DN50	4.25	108	2.516	64.0	1.975	50.0	0.37	0.82
2"	2 1/2"	4.13	105	3.047	77.5	2 3/8"	60.3	0.42	0.92
2"	DN65	4.13	105	3.047	77.5	2.600	66.0	0.40	0.88
2"	3"	4.53	115	3.579	91.0	2 7/8"	73.0	0.68	1.50
2"	DN80	4.53	115	4.176	106.0	3.191	81.0	1.12	2.47

*Fitting Lengths listed are for Corroflon braided only hose grades (SS, PB, HB, KYB). Approximately 33% longer lengths apply to the rubber covered hose grades (RC, SI, FP).

Corroflon 90° Elbow Triclover Fittings (90° Elbow Mini-Sanitary & Sanitary Triclamp Fittings)



End Fitting Specification

- BS4825 Pt 3
- ASME-BPE-a
- Others to Special Order

Temperature and Pressure Ratings

For Standard Clamp and Standard (EPDM) Gasket

- Pressures up to 16 Bar (230 psi)
- Temperatures up to 120°C (250°F)
- Higher Pressures and Temperatures with Special Clamps and Gaskets.

End Fitting Materials

- Fittings in Grade AISI 316L = EN 1.4404 = BS 316 S11
- Internal Bore average 15µin Ra, Electropolished if required
- Ferrules, most in Grade 304 SS, some sizes in Grade 316L SS

Outlet Diameters

The outlet diameters as listed are in accordance with BS4825. The ASME specification, however, requires these diameters to be 0.005" (0.125mm) less in each case. An Outlet Diameter tolerance of +0.000 -0.005" has therefore been applied, so that the same fitting satisfies requirements of both specifications.

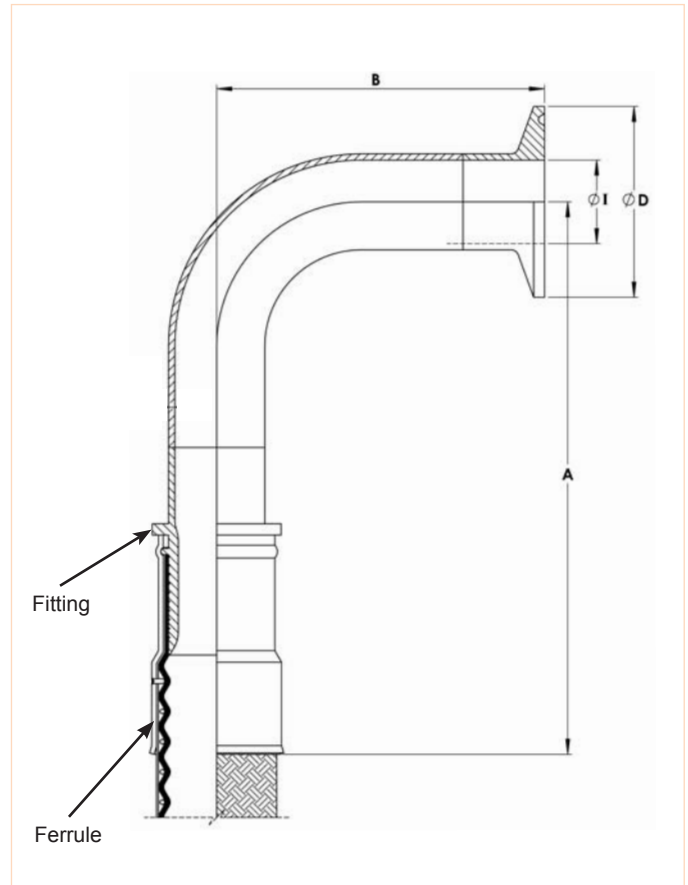

Nominal Hose Size		*Centre Line To Fitting End A		Centre Line to Face B		Flange Diameter D		*Outlet Diameter I		Weight of Fitting	
in	mm	in	mm	mm	mm	in	mm	in	mm	Kg	Lbs
1/2	13	5.78	147	1.60	41.0	0.984	25.0	3/8	9.5	0.137	0.30
3/4	20	6.41	163	1.60	41.0	0.984	25.0	5/8	16.0	0.205	0.45
1	25	6.53	166	2.00	51.0	1.984	50.5	7/8	22.2	0.347	0.77
1 1/2	40	7.99	203	2.75	70.0	1.984	50.5	1 3/8	34.9	0.590	1.30
2	50	9.33	237	3.50	88.9	2.519	64.0	1 7/8	47.6	0.928	2.05

*Fitting Lengths listed are for Corroflon braided only hose grades (SS, PB, HB, KYB). Approximately 33% longer lengths apply to the rubber covered hose grades (RC, SI, FP).

Corroflon DIN 11851 Fittings

PTFE Lined and Non-Lined

DIN11851 FITTINGS (MALE & FEMALE), PTFE LINED

Description

DIN 11851 male and female fittings, integrally PTFE lined.

Also available non-lined, up to 4" (100mm), to special order.

Specification

Generally to German DIN 11851 specification.

NB: The PTFE lined male fitting is designed to be used without a rubber seal. Please note that when connecting to a PTFE Lined DIN11851 Male, extra spanner tightening of the nut is sometimes required in order to provide a leak free connection.

End Fitting Materials

- Spigots in Grade 316L SS
- Nuts in Grade 304 SS
- Ferrules, most in Grade 304 SS, some sizes in Grade 316L SS

Temperature & Pressure Ratings

- Sizes up to 1 1/2" MWP = 40 Bar (580 psi) up to 130°C (266°F)
- Sizes 2" & 3" MWP = 25 Bar (360 psi) up to 130°C (266°F)

Except where the applicable hose pressure/temperature ratings are lower (page 8).

90° Elbows - PTFE Lined 90° elbow fittings are available for some sizes and grades - see page 29.



DIN11851 Female Fitting



DIN11851 Male Fitting

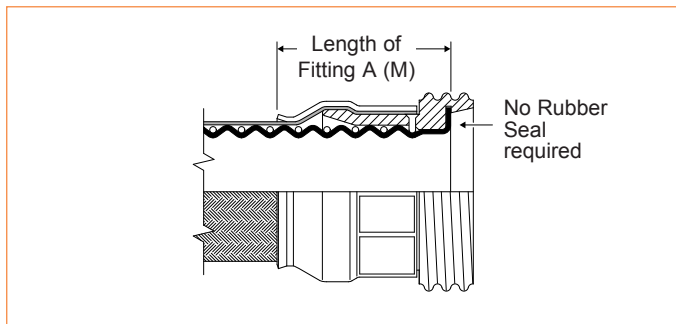
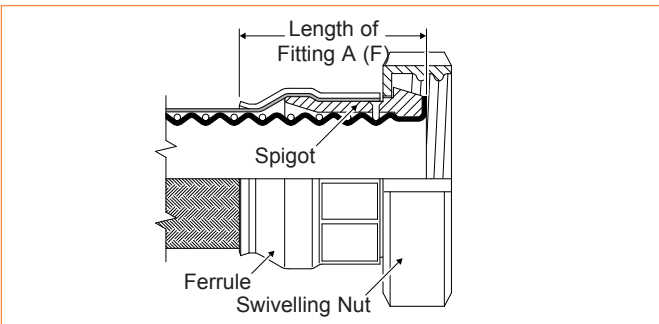

Nominal Hose Size		*Fitting Length (Male) A (M)		*Fitting Length (Female) A (F)		Weight of Fitting			
in	mm	in	mm	in	mm	Male		Female	
						Kg	Lbs	Kg	Lbs
3/4	20	2 3/8	60	2 3/8	60	0.18	0.39	0.22	0.48
1	25	2 3/8	60	2 5/8	67	0.22	0.48	0.36	0.79
1 1/4	32	2 1/2	65	2 3/4	70	0.27	0.59	0.47	1.04
1 1/2	40	2 5/8	67	2 7/8	73	0.33	0.73	0.55	1.21
2	50	2 5/8	67	2 7/8	73	0.58	1.28	0.93	2.05
2 1/2	65	3 1/2	89	3 5/8	92	0.73	1.61	1.31	2.88
3	80	4	100	3 5/8	92	1.00	2.20	1.57	3.46

*Fitting Lengths listed are for Corroflon braided only hose grades (SS, PB, HB, KYB). Approximately 33% longer lengths apply to the rubber covered hose grades (RC, SI, FP).

DIN11851 FEMALE FITTINGS, NOT PTFE LINED

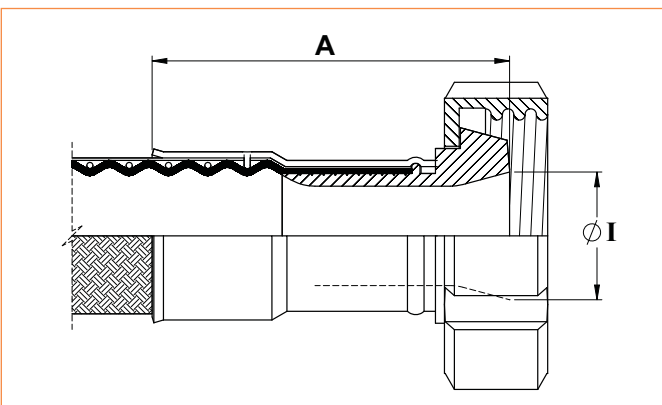

Description - DIN11851 Female Fittings, Non-Lined, are available in sizes 3/4", 1", 1 1/2", 2", 2 1/2", 3" and 4". Consult Aflex Hose for details.

Materials - Spigots in Grade 1.4571 (AISI 316 Ti), Nuts in Grade 304 SS, Ferrules, most in Grade 304 SS, some in Grade 316 SS.

Nominal Hose Size		ID (I)		Fitting Length (A)		Fitting Weight	
in	mm	in	mm	in	mm	Kg	Lbs
1/2	13	16	0.63	48	1.89	0.18	0.40
3/4	20	20	0.79	73	2.87	0.24	0.53
1	25	26	1.02	74	2.91	0.41	0.90
1 1/4	32	32	1.26	89	3.50	0.52	1.15
1 1/2	40	38	1.50	101	3.98	0.75	1.65
2	50	50	1.97	105	4.13	1.11	2.45

Corroflon SMS Female Fittings - PTFE Lined, RJT Female Fittings - Non Lined

End Fitting Specification

- SMS generally to Swedish SMS1148 specification.
- RJT generally to British BS4825 Pt 5 specification.

Temperature and Pressure Ratings

- Pressures up to 10 Bar (150 psi)
- Temperatures up to 150°C (302°F)

End Fitting Materials

- Spigots in Grade 316L SS
- Nuts in Grade 304 SS
- Ferrules, most in Grade 304 SS, some sizes in Grade 316L SS

90° Elbows

- PTFE Lined 90° elbow fittings are available for some sizes and grades
- see page 29.

SMS FEMALE FITTINGS

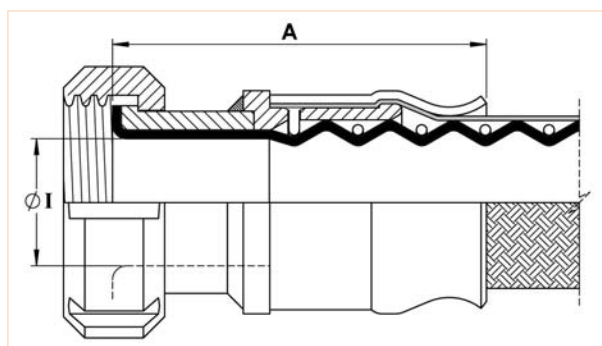

Nominal Size		*Length A		Outlet Dia. I		Weight of Fitting	
in	mm	in	mm	in	mm	Kg	Lbs
1	25	3 ¹ / ₈	79	1	25	0.60	1.32
1 ¹ / ₂	40	3 ¹ / ₂	89	1 ¹ / ₂	38	0.98	2.16
2	50	3 ³ / ₄	95	2	50	1.22	2.69
2 ¹ / ₂	65	4 ⁵ / ₈	116	2 ¹ / ₂	63	1.549	3.41
3	80	4 ³ / ₄	122	3	75	1.997	4.40

RJT FEMALE FITTINGS

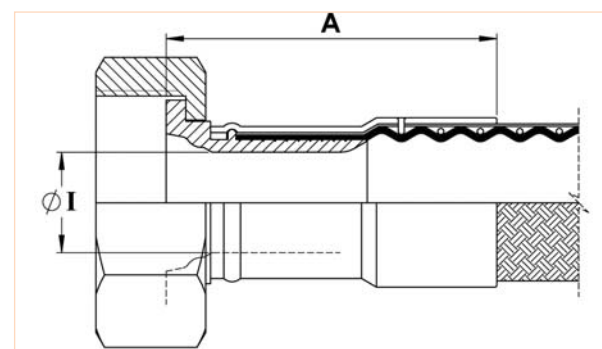

Nominal Size		*Length A		Outlet Dia. I		Weight of Fitting	
in	mm	in	mm	in	mm	Kg	Lbs
1	25	2.68	68	0.80	20.24	0.27	0.6
1 ¹ / ₂	40	3.78	96	1.25	31.75	0.49	1.08
2	50	3.90	99	1.75	44.45	0.67	1.48
2 ¹ / ₂	65	4.09	104	2.25	57.15	0.78	1.72
3	80	4.21	107	2.63	66.7	0.89	1.96

*Fitting Lengths listed are for Corroflon braided only hose grades (SS, PB, HB, KYB). Approximately 33% longer lengths apply to the rubber covered hose grades (RC, SI, FP).

Corroflon NPT and BSPT Fixed Male and NPT Fixed Female Fittings

End Fitting Specification

- NPT Taper Threads to American National Standard Pipe Taper Thread design to ANSI/AMSE B1.20.1
- BSPT Threads to British Standard Pipe Taper Thread design to BS21
- Alternatives - Parallel Threads, Metric Threads and Others.

End Fitting Materials

- Fittings in Grade 316L SS
- Ferrules, most in Grade 304 SS, some sizes in Grade 316L SS
- Alternatives - Fittings in Zinc Plated Carbon Steel

FIXED MALE NPT or BSPT

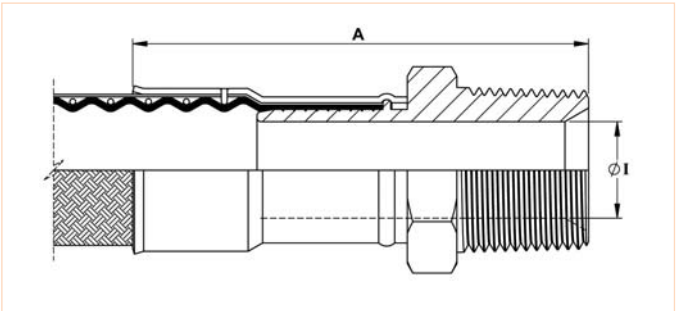

Nominal Hose Size		*Fitting Length A		Inside Diameter I		Weight of Fitting	
in	mm	in	mm	in	mm	Kg	Lbs
1/2	15	2 5/8	67	0.38	9.53	0.10	0.22
3/4	20	3 1/2	89	0.63	15.88	0.18	0.40
1	25	3 7/8	98	0.80	20.24	0.29	0.64
1 1/4	32	4 3/8	110	1.03	26.21	0.45	0.99
1 1/2	40	5 1/8	130	1.25	31.75	0.60	1.32
2	50	5 1/2	140	1.75	44.45	0.84	1.85
2 1/2	65	6 3/4	170	2.25	57.15	1.70	3.75
3	80	6 3/4	170	2.63	66.70	2.53	5.58
4	100	7 1/2	190	3.50	88.90	3.99	8.80

*Fitting Lengths listed are for Corroflon braided only hose grades (SS, PB, HB, KYB). Approximately 33% longer lengths apply to the rubber covered hose grades (RC, SI, FP).

FIXED FEMALE NPT

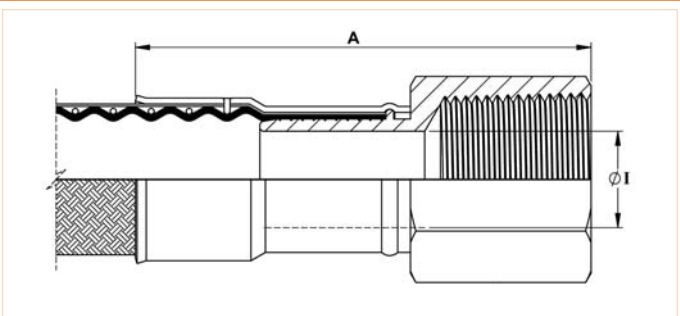

Nominal Hose Size		NPT or BSPT Thread Size	*Fitting Length A		Fitting Inside Diameter I		Weight of Fitting	
in	mm	in	in	mm	in	mm	Kg	Lbs
1/2	13	1/2	2.72	69	0.38	9.53	0.18	0.40
3/4	20	3/4	3.54	90	0.63	15.88	0.22	0.49
1	25	1	3.82	97	0.80	20.24	0.33	0.73
1 1/2	40	1 1/2	4.96	126	1.25	31.75	0.75	1.65
2	50	2	5.16	131	1.75	44.45	1.06	2.34

*Fitting Lengths listed are for Corroflon braided only hose grades (SS, PB, HB, KYB). Approximately 33% longer lengths apply to the rubber covered hose grades (RC, SI, FP).

Corroflon BSP 60° Cone Seat Female Unions and BSP Flat Seat Lug Nut Female Fittings

End Fitting Specification

- BSPP Threads to British Standard Pipe Parallel Thread design to BS21, 60° Cone Seat design, or Flat Seat.

Alternatives - Cone Seat Female Union Fittings can be supplied with a BSPP/BSPT Taper Male Adaptor if required.

Available in sizes up to 4"

End Fitting Materials

- Spigots in Grade 316L SS
- Nuts in Grade 316L SS
- Ferrules, most in Grade 304 SS, some sizes in Grade 316L SS

Alternatives

- Cone Seat Female Unions can be supplied in Zinc Plated Carbon Steel if required.
- Lug Nuts can be supplied in Gun Metal (Bronze) if required.

BSP 60° CONE SEAT FEMALE UNION FITTING

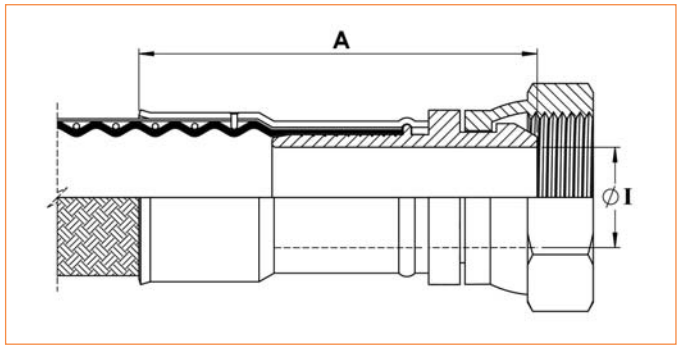
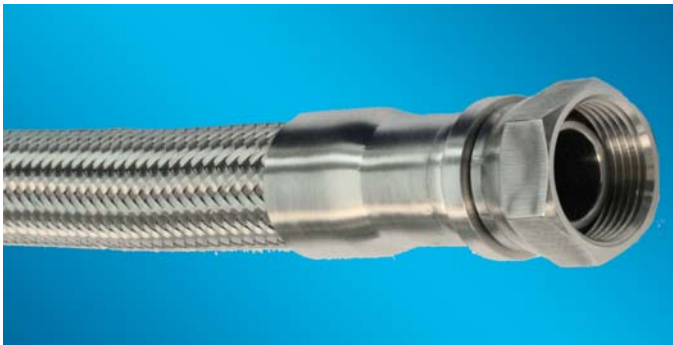

Nominal Hose Size		NPT or BSPT Thread Size	*Fitting Length A		Fitting Inside Diameter I		Weight of Fitting	
in	mm		in	mm	in	mm	Kg	Lbs
1/2	13	1/2	2 1/2	63	0.37	9.35	0.11	0.25
3/4	20	3/4	3 1/2	89	0.63	15.88	0.15	0.34
1	25	1	3 1/2	89	0.80	20.24	0.24	0.53
1 1/2	40	1 1/2	3 7/8	98	1.25	31.75	0.72	1.59
2	50	2	4	100	1.75	44.45	0.99	2.19

BSP FLAT FACE LUG NUT FEMALE FITTING

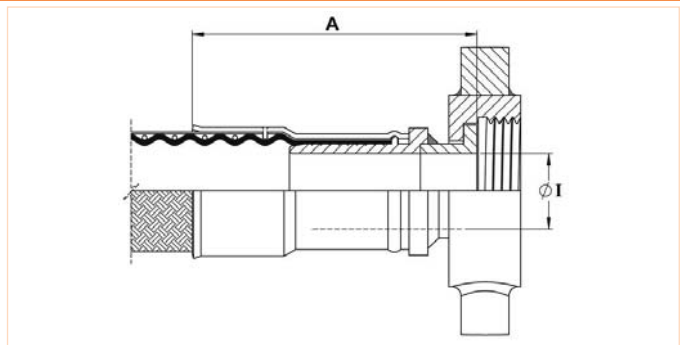

Nominal Hose Size		BSPP Thread Size	*Fitting Length A		Fitting Bore Diameter I		Weight of Fitting	
in	mm		in	mm	in	mm	Kg	Lbs
1	25	1	2.72	69	0.80	20.24	0.25	0.55
1 1/2	40	1 1/2	3.78	96	1.25	31.75	0.61	1.33
2	50	2	3.90	99	1.75	44.45	0.88	1.95

*Fitting Lengths listed are for Corroflon braided only hose grades (SS, PB, HB, KYB). Approximately 33% longer lengths apply to the rubber covered hose grades (RC, SI, FP).

Corroflon 37° JIC Female Fittings and NPT Male or Female Unions

End Fitting Specification

- SAE J514 37° Flare JIC Female Fitting
- 37° JIC Male-to-NPT Male/Female Adaptors
- NPT Threads to ANSI B2.1

Temperature and Pressure Ratings

Same Maximum Working Pressure and Temperature as for the relevant size of Corroflon Hose, on page 7.

End Fitting Materials

- Spigots in Grade 316L SS
- Nuts in 316L SS
- Ferrules, most in Grade 304 SS, some sizes in Grade 316L SS

Note - Not usable with SAE 45° Flare fittings which have the same thread..

Alternatives - Can be supplied in other materials, such as zinc plated carbon steel, Hastelloy, Monel etc.

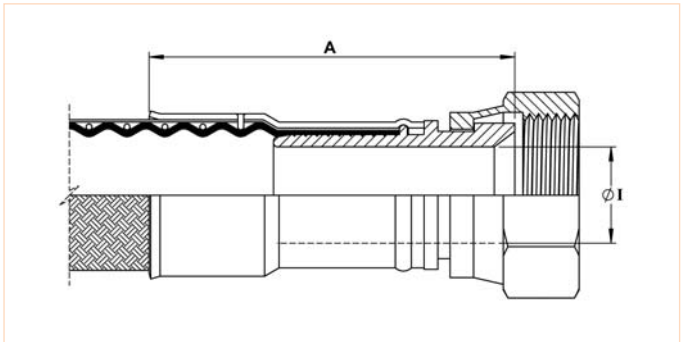

Nominal Hose Size		37° JIC Thread Size	*Fitting Length A		Hex Size H		Fitting Inner Diameter I		Weight of Fitting	
in	mm	in	in	mm	in	mm	in	mm	Kg	Lbs
1/2	13	3/4 -16	2.13	54	0.88	22.2	0.38	9.5	0.11	0.24
3/4	20	11/16 -12	2.99	76	1.25	31.7	0.63	15.9	0.15	0.34
1	25	15/16 -12	3.66	93	1.50	38.1	0.80	20.2	0.23	0.52
1 1/2	40	17/8 -12	4.17	106	2.25	57.1	1.25	31.7	0.72	1.58
2	50	2 1/2 -12	4.49	114	2.88	73.0	1.75	44.4	0.99	2.18

*Fitting Lengths listed are for Corroflon braided only hose grades (SS, PB, HB, KYB). Approximately 33% longer lengths apply to the rubber covered hose grades (RC, SI, FP).

JIC TO NPT MALE UNION (Including a JIC MALE-TO-NPT MALE ADAPTOR)

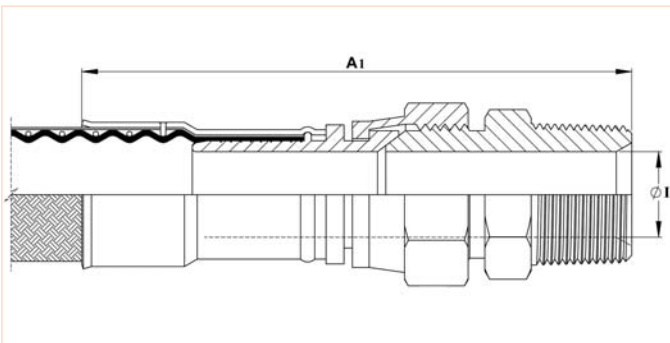

Nominal Hose Size		*Male Union Length A1		Weight of Fitting	
in	mm	in	mm	Kg	Lbs
1/2	13	4.13	105	0.22	0.48
3/4	20	4.92	125	0.33	0.72
1	25	5.43	138	0.52	1.15

JIC TO NPT FEMALE UNION (Including a JIC MALE-TO-NPT FEMALE ADAPTOR)

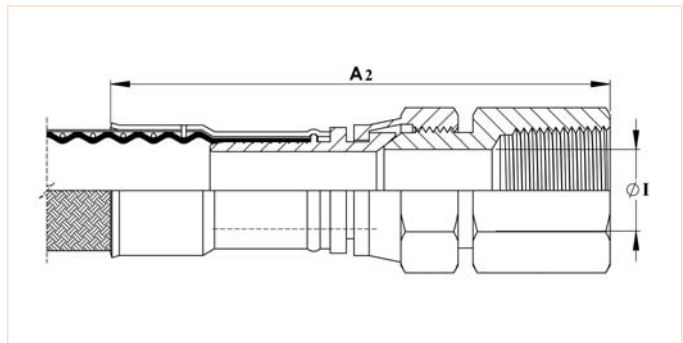

*Female Union Length A2		Fitting Inner Diameter I		Weight of Fitting	
in	mm	in	mm	Kg	Lbs
3.62	92	0.38	9.5	0.21	0.47
4.80	122	0.63	15.9	0.33	0.74
5.35	136	0.80	20.2	0.68	1.50

*Fitting Lengths listed are for Corroflon braided only hose grades (SS, PB, HB, KYB). Approximately 33% longer lengths apply to the rubber covered hose grades (RC, SI, FP).

Corroflon PTFE Dip Pipes, Straight or 90° Elbow

FIXED DIP PIPES

Description

Fixed Dip Pipes are fairly rigid, thick wall PTFE tubes, either straight or 90° elbowed, which are directly crimped to the end of Corroflon hoses. They are designed for insertion into drums, tanks and reaction vessels in order to suction drain (or inject) process fluids transferred through the hose.

Materials

- Standard dip pipes are in anti-static (AS) PTFE
- Ferrules, most in Grade 304 SS, some sizes in Grade 316L SS

How to order

Specify the size and material of the dip pipe, whether it is straight or 90° elbowed. Give the length of the straight leg of the dip pipe and the length of the rest of the hose assembly separately.



Maximum Working Pressures

Dip Pipes are normally only tested to 4 Bar Pressure, and are not suitable for use at pressures higher than 3 Bar. They are usable at negative pressure up to full vacuum.

If higher pressure ratings are required, consult Aflex Hose.

Lengths

Dip Pipes are supplied as standard in 1 metre straight lengths, but can be supplied in any length to individual requirements.

Nominal Hose Bore Size		Approximate Dip Pipe Dimensions			
		Outside Diameter D		Inside Diameter I	
in	mm	in	mm	in	mm
3/4	20	0.87	22	0.51	13
1	25	1.14	29	0.83	21
1 1/2	40	1.54	39	1.00	27
2	50	2.17	55	1.58	40

FIXED DIP PIPE (STRAIGHT)

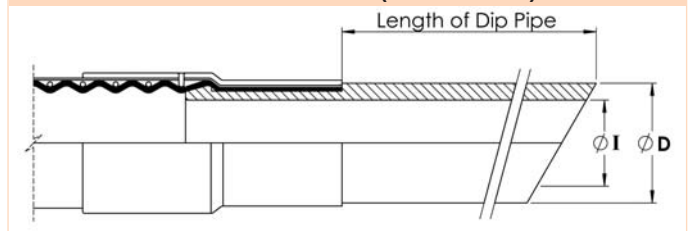

DETACHABLE DIP PIPES

Description

As Fixed Dip Pipes above, but connected to the hose through an end fitting, not by crimping direct to the hose.

Design

A straight, or 90° elbowed anti-static PTFE Dip Pipe, fitted with a Flange or Cam & Groove Male PTFE Lined & Flared end fitting.

The most usual end fitting is a Cam Male (as shown), so the dip pipe can then be connected to a hose with a Cam Female end fitting.

Specifications

As above for Fixed Dip Pipes.

DETACHABLE DIP PIPE

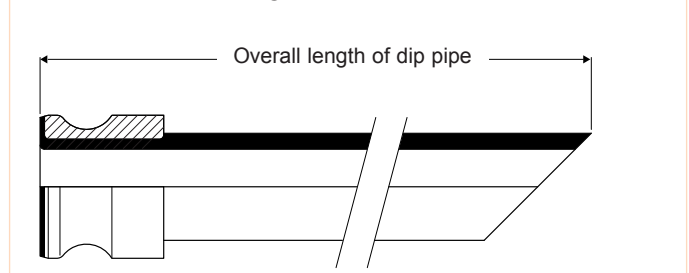

Corroflon 90° Elbow Fittings, PTFE Lined and Non-Lined

PTFE LINED 90° ELBOW FITTINGS

Scope - All of the PTFE lined end fittings described on previous pages can be fitted as 90° elbow PTFE lined fittings to the design shown, to the sizes listed.

- All grades of hose can be used, except PB and KYB.

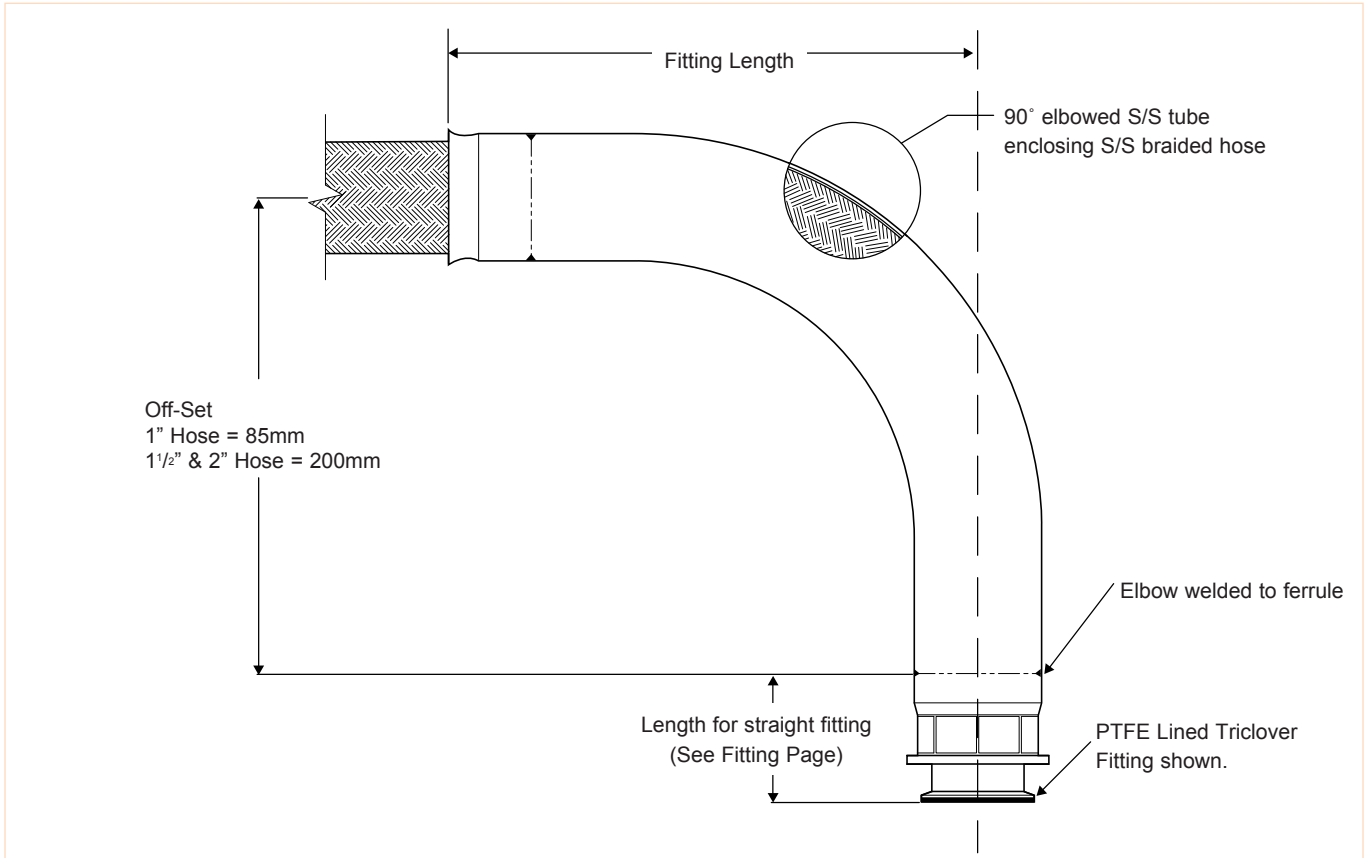

Hose Bore Sizes	Off-Set	Fitting Length	Weight of Fitting	
			Kg	Lbs
1"	85	143	0.48	1.07
1 1/2"	200	237	1.37	3.03
2"	200	314	1.68	3.70

NON-LINED 90° ELBOW END FITTINGS

A 90° elbow attached to the hose can be supplied non-PTFE lined, as shown, for any size or grade of hose or type of fittings, to special order.

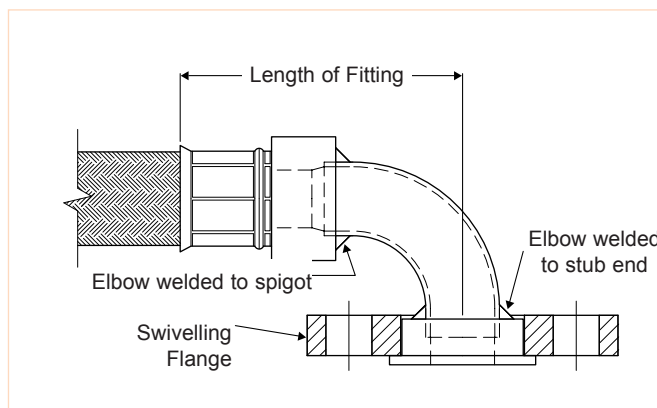

Corroflon Steam Heated Hose Assemblies. (CH Grade)

CH Hose Assembly

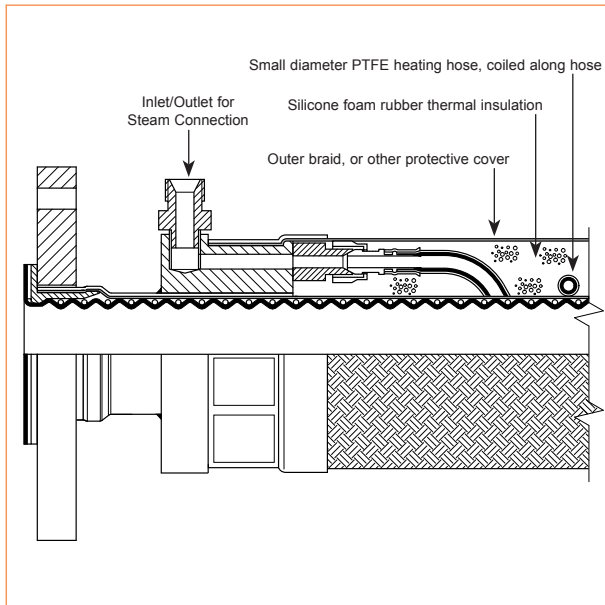

Purpose

For use in applications where the temperature of the process fluid entering the hose assembly must be maintained as it passes through the hose. This is usually required to prevent solidification or an increase in the fluid viscosity. Steam or hot oil heating is preferred to electrical heating in some applications for reasons of availability or safety, but is less controllable.

Description

The heating element comprises a small diameter PTFE heating hose, 6mm or 9.5mm bore size, with a single SS wire braid. This is spirally wrapped around the hose, with inlet and outlet ports attached either both at one end or at opposite ends of the hose assembly. In the case of hose assemblies longer than 3 metres, it is usual to have not one but several heating hoses with inlet ports at opposite ends and along the hose. This reduces the effects of temperature loss over the length of the hose assembly. The thermal insulation is closed-cell, fire resistant silicone foam rubber. The outer cover may be SS wire braid with or without a rubber cover if necessary.

Design

Each hose is custom designed and built to suit the requirements of the particular application. The following information is therefore required:

Fluid in Hose Assembly

Maintained Temperature of Fluid in Hose

Temperature of Steam or Fluid in the Heating Hose

Min/Max Ambient Temperature

External Conditions of Abrasion etc

Specifications

As for Corroflon GP, SS on page 7, except the size range is 1" to 3", the minimum bend radius is tripled, and the outside diameter and weight are significantly increased in line with the particular design.

Limitations

1" PTFE lined PN10 flange spigots on heated hoses can only have a maximum flare diameter of 50mm, not 63mm.

If the hose is "hanging", straight or at 90°, under its own weight, special construction is required, so advise Aflex Hose accordingly.

Minimum CH Hose Assembly Length 750mm.

Not recommended for use with PB braid.

Corroflon Electrically Trace Heated Hose Assemblies. (ETH Grade)

Purpose

For use in applications where the temperature of the process fluid entering the hose assembly must be regulated as it passes through the hose. This is usually required to prevent solidification or an increase in the fluid viscosity. In some applications, an additional 'heating up' or 'melting' facility is also required. Electrical heating is often preferred to steam heating because it is more convenient, more controllable and usually more readily available. 'Zone 1 Hazardous Area' requirements can be met.

Description

The heating element comprises either a resistance element or a self-regulating element spirally wrapped around the hose assembly. Self regulating elements may require a sensor and controller if a specific maintain temperature is required. Please consult Aflex Hose for clarification. Resistance element heated hoses usually also require a temperature sensor to be built in to the construction and must be used in conjunction with a temperature controller. The power leads and (if applicable) temperature sensor leads emerge from the hose assembly at one end, through glands and conduits. The thermal insulation is foam rubber, closed-cell fire resistant silicone foam rubber for temperatures above 80°C. The outer cover may be a Polypropylene Braid or SS wire braid with a rubber cover if necessary.

Design

Each hose is custom designed and built to suit the requirements of the particular application. Application details must be supplied by filling in an "ETH Hose Questionnaire", available from Aflex Hose. Generally, for Hazardous Areas, the Self Regulating type of heating element is employed, with or without a temperature sensor and control, and flameproof glands and conduit are also required. The watts per metre of the heating element, the pitch of the spiral on the hose, and the thickness of the thermal insulation are all calculated in accordance with established formulae to give the required maintained temperature for the process fluid passing through.

Specifications

As for Corroflon GP, SS on page 7, except that the minimum bend radius is tripled and the outside diameter and weight are significantly increased in line with the particular design. Maximum ETH Hose Assembly Lengths are as given for Corroflon GP, SS.

Limitations

1" PTFE lined PN10 flange spigots on heated hoses can only have a maximum flare diameter of 50mm, not 63mm.

If the hose is "hanging", straight or at 90°, under its own weight, special construction is required, so advise Aflex Hose accordingly.

Minimum ETH Hose Assembly Length, when collars are used 750mm.

ETH Hose Assembly

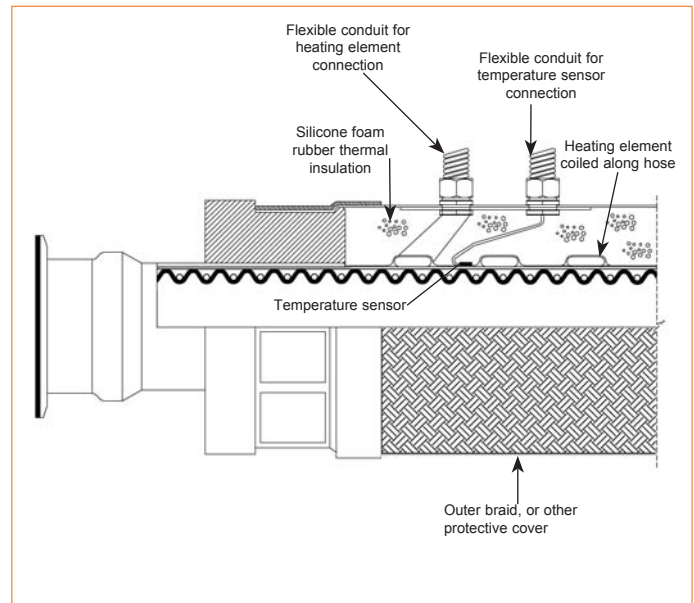

Corroflon Standard Labelling, Streamline Tagging and Colour Coding Systems

Standard Labelling

All Corroflon hose assemblies are labelled with the following information:

- Manufacturer's Name
- Hose Size and Grade
- Max. Working Pressure
- Unique Serial Number
- Month & Year of Manufacture
- Telephone Number
- CE Mark (if applicable)

This information is normally laser-etched on to a loose stainless steel Ring mounted on the hose.

In some cases, at the discretion of Aflex Hose, the information may be etched on to a thin stainless steel plate which is clamped to the hose, or on to the end fitting ferrule at one end. This may be necessary for example, if the customer requires additional information which may not fit on to a Ring.

Customers may specify which labelling system they require, and may request additional information on the label.



Streamline Tagging

This system is only applicable to the Silicone (SI) rubber covered grades of Corroflon that have a stainless steel (SS) braid.

A label and/or Colour Code is placed around the silicone cover of the hose and then encapsulated by a transparent silicone that is formed into a thin streamlined cover.

Note: 1/2" size, Colour Code only, no text.

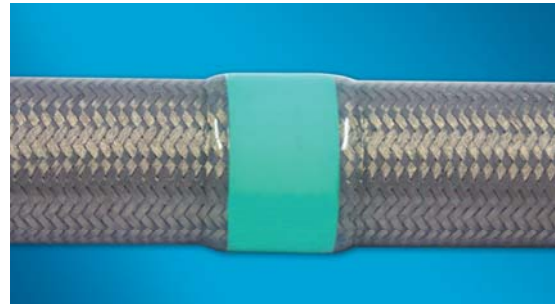

Colour Coding

This system is applicable to all grades of Corroflon hose.

A coloured PTFE spiral strip is wound on to the hose.

It can be left loose, or it can be encapsulated under a transparent, heat-shrunk polyolefin sleeve.



Correct Hose Configuration & Length Calculations - for Bend Radius

Hose Configuration Requirements

Hose Assemblies are usually connected at both ends in service. They may then either remain in a fixed, or static configuration or in a flexing, or dynamic configuration.

Whether static or dynamic, the First Rule concerning the configuration of the hose is that **the bend radius of the hose must never be less than the Minimum Bend Radius (MBR) for the hose** as listed in the relevant hose brochure.

The most common situation when this is likely to occur is when the hose is flexed at the end fitting, with stress being applied to the hose at an angle to the axis of the end fitting. Typically, this happens either because the length of the hose is too short, or because the weight of the hose plus contents creates a stress at an angle to the end fitting.

The Second Rule, therefore, if possible, is to **design the configuration to ensure that any flexing in the hose takes place away from the end fittings.**

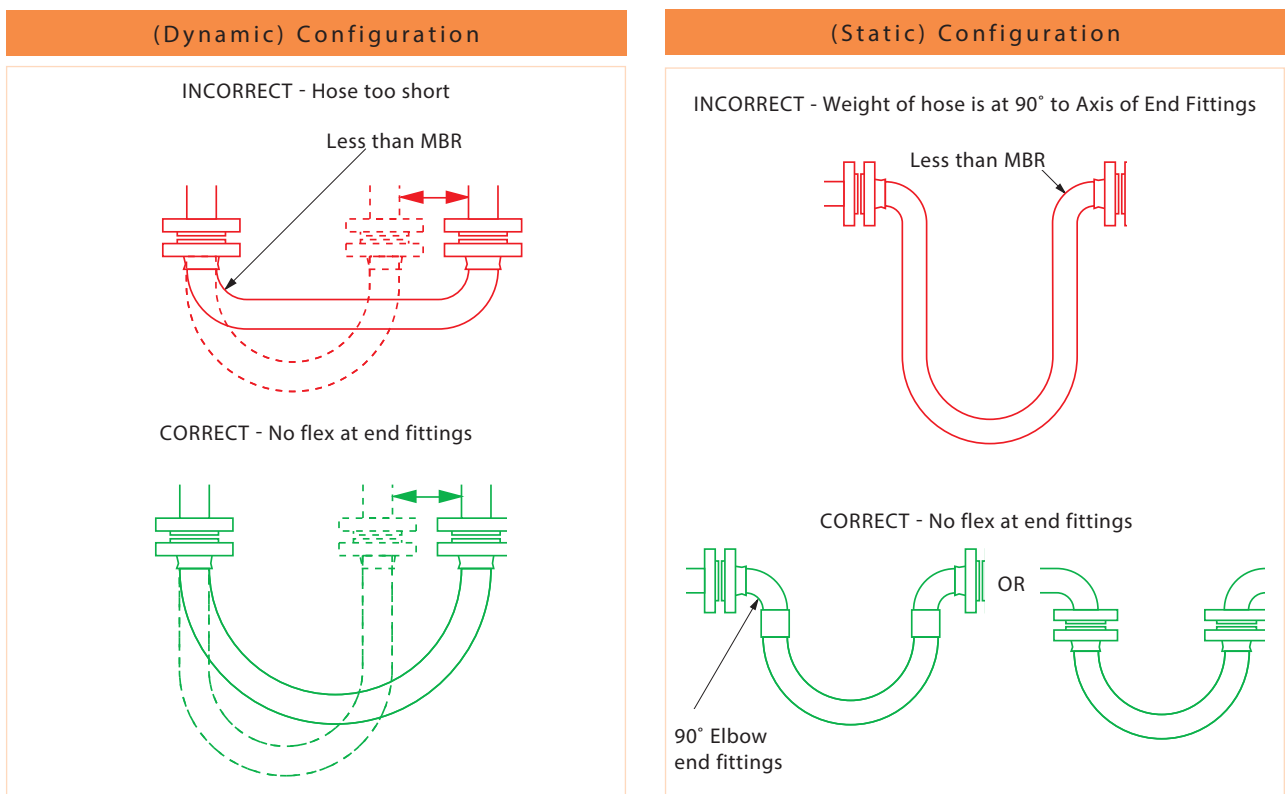

Correct Hose Configuration & Length Calculations - for Abrasion & Torque

The Third Rule is that **the hose configuration should always be designed, and supported where necessary, to avoid any possibility of external abrasion.**

In some cases, the length, configuration and angle of the hose can be designed to avoid abrasion. In others, static or moving support frames or support wheels are required.

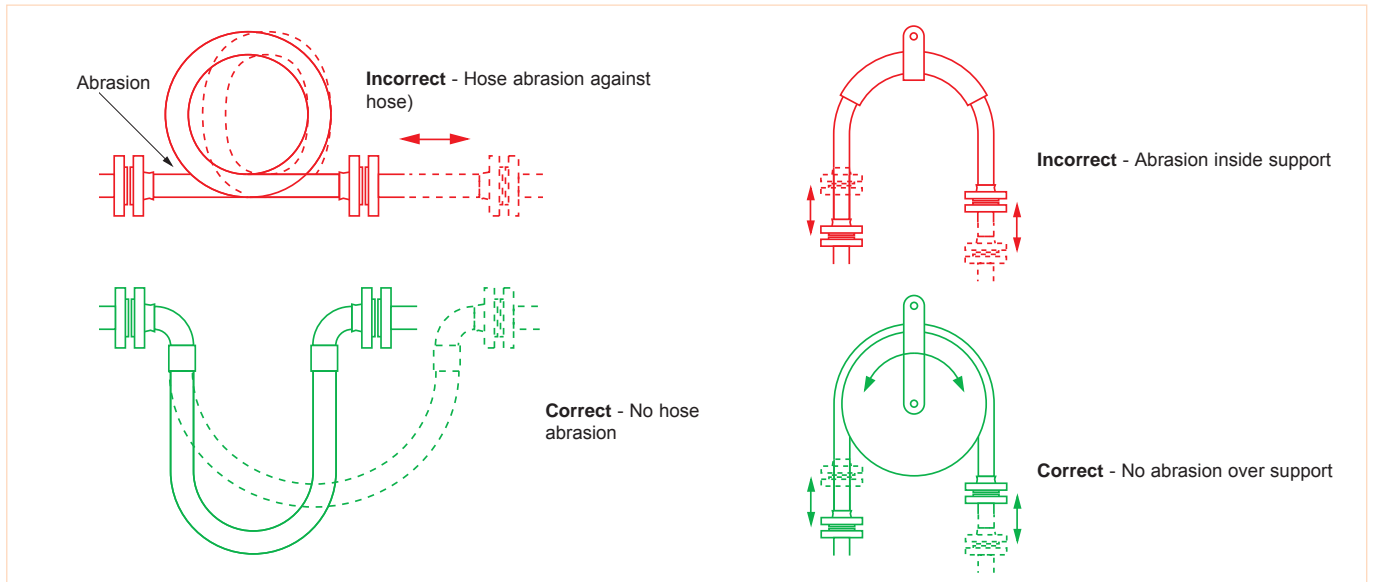

The Fourth Rule is that **the hose must not be subjected to torque, either during connection, or as a result of the flexing cycle.**

Torque (twist) in the hose can be applied during connection if the hose is accidentally twisted, or if the second end being connected is a screwed connection, and the hose is subjected to torque during final tightening.

In a flexing application, if any flexing cycle of the hose occurs in 3 dimensions instead of 2, then torque will also occur:

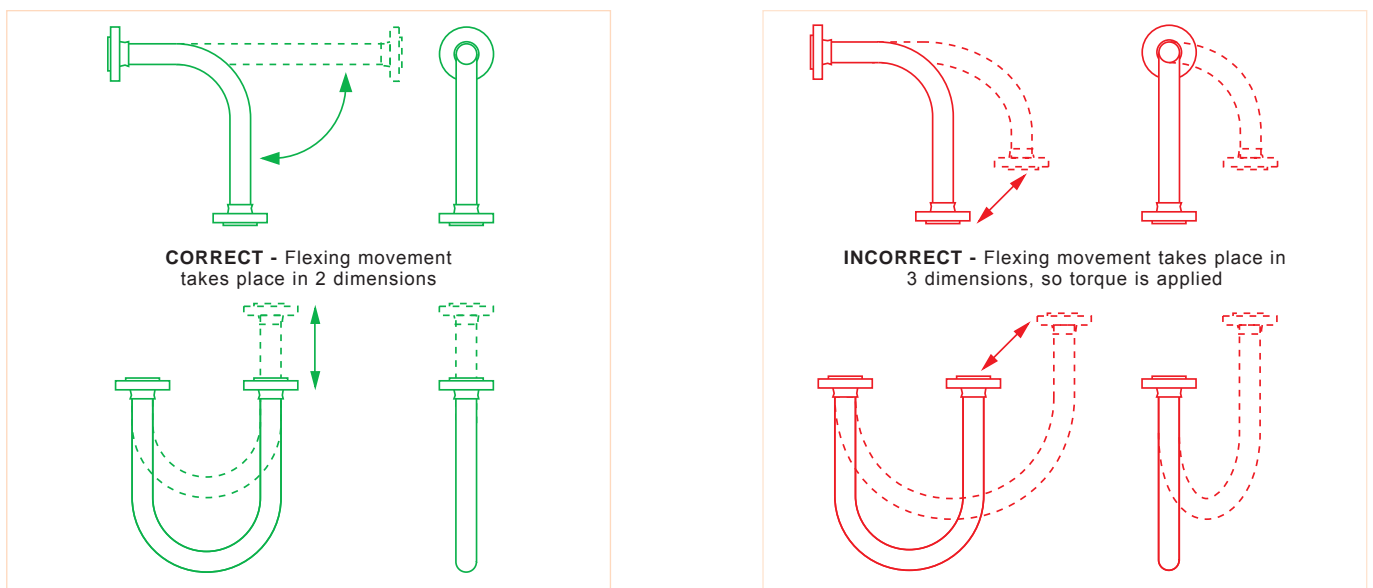

Both Corroflon and Bioflex hose have good resistance to a small level of torque, much better resistance than rubber or SS hose types, but it is still the best practice to take whatever steps are necessary to eliminate torque. If in doubt, consult Aflex Hose.

Hose Configurations & Length Calculations

- for Length Calculation

Calculating the Hose Length

The formula for calculating the bent section of the hose length around a radius is derived from the basic formula that the circumference of a circle = $2\pi R$, where R = the radius of the circle, and π = a constant, = 3.142.

So, if the hose goes around a 90° bend, which is $1/4$ of a full circumference, and the radius of the bend is R , then the length of the hose around the bend is = $1/4 \times 2\pi R$. Or half way round, in a U-shape, = $1/2 \times 2\pi R$.

Note :

In calculating the length of a hose assembly, the (non-flexible) length of the end fittings must be added in, also the length of any straight sections of hose, as in the following example:

Example :

To calculate the length for a 2" bore size hose with flange end fittings, to be fitted in a 90° configuration with one leg 400mm long, the other 600mm long.

$$\begin{aligned} \text{Length of Bent Section (yellow)} &= 1/4 \times 2\pi R \text{ (334)} \\ &= 1/4 \times 2 \times 3.142 \times 334 = \mathbf{525\text{mm}} \end{aligned}$$

$$\begin{aligned} \text{Length of top, Straight Section, including the top end fitting length} \\ &= 600 - 334 = \mathbf{266\text{mm}} \end{aligned}$$

$$\text{Length of bottom end fitting} = \mathbf{66\text{mm}}$$

$$\text{Total length of Hose Assembly} = 525 + 266 + 66 = \mathbf{857\text{mm}}$$

Things to consider

- A hose will normally take the longest radius available to it to go around a corner, not the MBR! Also - always remember to include the **non-flexible** end fitting lengths.
- In dynamic applications, remember to always calculate the lengths for the most extended configuration during the flexing cycle, not the least extended.
- If the configuration is simply too complex for calculation, then obtain a length of flexible tubing of some kind, mark on paper, or a wall, or floor, or both where the connection points will be relative to each other, scaled down if necessary, then manually run the flexible tubing between them with full radii round bends. Measure the extended length, then scale up if necessary to determine the approximate length of the hose.

If in doubt, consult Aflex Hose.

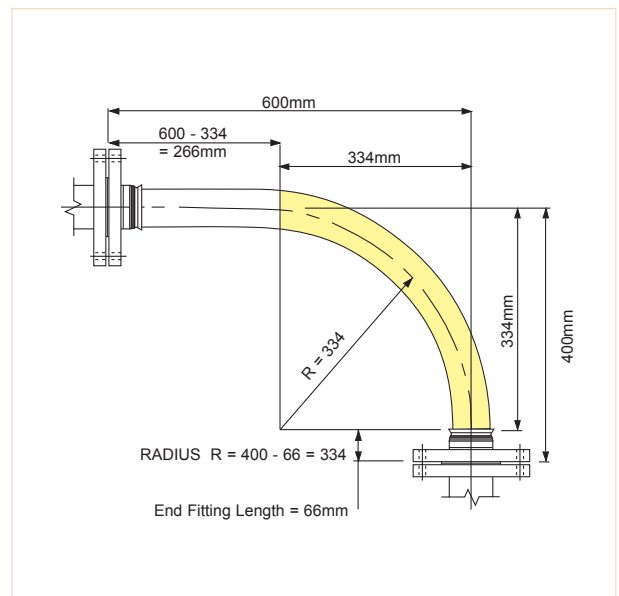
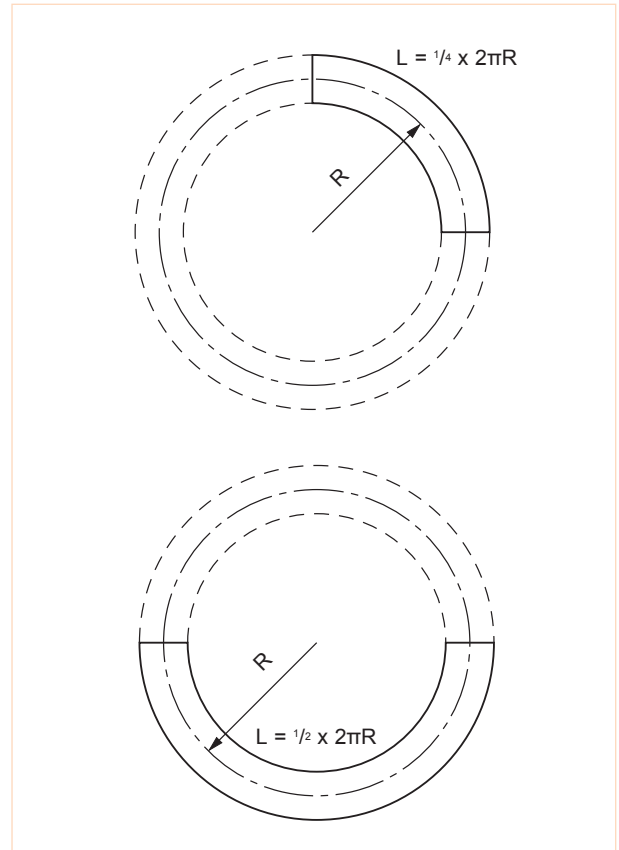

Conditions of Sale

Definitions

- (1) "Aflex Hose" shall mean Aflex Hose Limited
- (2) "Aflex Hose Products" shall mean those products the Customer is purchasing from Aflex Hose.
- (3) "Customer" shall mean the individual or entity that is purchasing Aflex Hose Products hereunder.
- (4) "Full Product Brochure" shall mean the brochure for each specific product available at <http://www.aflex-hose.com/products/>.

General

(5) These Conditions of Sale form the basis of the contract of sale between Aflex Hose and the Customer. In the event of any conflict between the terms and conditions set forth in these Conditions of Sale and any other Customer document, these Conditions of Sale shall govern, unless otherwise agreed to in writing and authorized and signed for by a Director or General Manager of Aflex Hose.

(6) Unless otherwise agreed to in writing, delivery will be at cost from Aflex Hose's facilities Brighouse, West Yorkshire, England. Title and all risks of loss or damage pass to the Customer upon delivery to the Customer or third party carrier. Delivery dates specified by Aflex Hose are only Aflex Hose's best estimates and Aflex Hose's only responsibility will be to use reasonable commercial efforts to meet all specified delivery dates.

Customer Responsibilities and Obligations

(7) It is the Customer's strict responsibility to review all of the usage conditions and usage limitations given for the Aflex Hose Products which are intended for use in a particular application, to ensure that the application conditions are in compliance with those usage limitations. The usage conditions and limitations are referred to in these Conditions of Sale, and are further specified in the relevant Full Product Brochure. The Customer shall consult the latest, up to date hose product information and Full Product Brochure at the time of ordering, which are only available and downloadable from the Aflex Hose website at <http://www.aflex-hose.com/products/>, or on request from Aflex Hose. The Customer here represents and warrants that it has read and understands the applicable Full Product Brochure and the usage conditions and the usage limitations set forth therein, and has ensured their compliance with the application conditions.

(8) If the Customer sells or assigns any Aflex Hose Products to any other person or entity, the Customer shall ensure that the final end user of the Aflex Hose Products is supplied with these Conditions to Sale, the applicable Full Product Brochures, the Aflex Hose website address, together with notification of the requirement to review the usage conditions and limitations. The Customer shall include the terms and conditions set forth herein in its Conditions of Sale to any third party. The Customer hereby agrees and acknowledges that Aflex Hose shall have no liability whatsoever for claims arising in whole or in part out of the Customer selling or assigning the Aflex Hose Products to a third party that does not use the Aflex Hose Products in accordance with Aflex Hose's usage requirements and limitations ("Non-Conforming Use Claims"). The Customer shall indemnify and hold harmless Aflex Hose, its officers, directors, employees, affiliates and representatives for any and all claims, damages, penalties and losses arising out of or related to Non-Conforming Use Claims.

(9) The Customer agrees and acknowledges that for any intended hose application in which special conditions apply which are not defined, or not defined sufficiently in the Product Brochure, the Customer shall write to Aflex Hose requesting written advice relating to any usage limitations resulting from special conditions. The Customer shall ensure the design suitability and safety of the Aflex Hose Products in their intended applications, giving particular consideration to any special condition relating to, but not restricted to the chemical and electrostatic compatibility of the fluids or gases passing through, the possibility of diffusion of fluid or gases through the PTFE hose lining, the possibility of external corrosive conditions, the types and likelihood of excessive mechanical abuse, such as abrasion (internal or external), crushing, excessive flexing or vibrations, etc. and any excessive temperature and/or pressure "pulsing" conditions, or any other condition which may cause premature hose failure. The Customer shall consider, and take account of the degree of risk involved in any hose failure, including the provision of adequate protection in the event of any risk to any persons. In applications where any type of hose

failure would lead to financial losses if the hose is not replaced immediately, the Customer agrees and acknowledges that it shall be the Customer's responsibility to order and hold in stock spare hose(s) accordingly. The Customer shall advise Aflex Hose in writing at the time of placing the enquiry and on any purchase order if there are any special requirements for the hose, including special cleaning, or drying, or extra testing requirements which are in addition to normal industrial standards. The Customer agrees and acknowledges that Aflex Hose, its officers, directors, employees, affiliates and representatives shall not be held liable for any claims or obligations arising out of the Customer's failure to fulfill any or all of its responsibilities set forth in this Section 9.

(10) If the Customer has any doubts concerning these or any other usage conditions and limitation or safety parameters, the Customer shall consult Aflex Hose at the number and address in the Notice Provisions below and request a written response to any queries.

Hose Service Life; 24 Month Warranty

(11) It is not possible to guarantee a minimum service life for any of the Aflex Hose Products which can be applicable for every type of application. As such, Customer acknowledges that, except as provided below in Sections 12, 13 and 14 Aflex Hose is not guaranteeing a minimum service life of any of the Aflex Hose Products.

(12) Service life predictions or guarantees can only be given in cases where all the relevant information concerning the application is given in writing to Aflex Hose, and Aflex Hose subsequently replies in writing with the service life prediction prior to the order being placed.

(13) If such a written undertaking is not sought and given, Aflex Hose shall not be held liable for any Aflex Hose Product failure which the Customer considers to be premature, excepting failures which are due to faulty materials or manufacturing defects which occur within 24 months or 12 months, as applicable, of supply as provided in Section 14 below.

(14) Aflex Hose warrants its Aflex Hose Products to be free from faulty materials or manufacturing defects from the date of the delivery, for 24 months; provided, however, that all Hose Assemblies which are "ETH" (Electrical Trace Heated) Grade are only warranted for 12 months.

(15) AFLEX HOSE MAKES NO WARRANTY OF ANY KIND WHATSOEVER, EXPRESS OR IMPLIED OTHER THAN AS SPECIFICALLY STATED HEREIN, AND THERE ARE NO WARRANTIES OF MERCHANTABILITY AND/OR FITNESS FOR A PARTICULAR PURPOSE WHICH EXCEED THE OBLIGATIONS AND WARRANTIES SPECIFICALLY STATED HEREIN.

Product Failure

(16) In the event of a product failure during the applicable warranty period set forth in Section 14, the Customer shall provide Aflex Hose with written notification within forty-eight (48) hours of discovering the fault. Aflex Hose requires that the Aflex Hose Products not be cut up or tampered with, but should be decontaminated and returned to Aflex Hose, plus a decontamination certificate, for examination and analysis of the fault. The Customer should also provide full details in writing of the application conditions under which the hose failed, including Pressure, Vacuum, Temperature, Flexing and any cycling of any of these, also the fluids, gases and any cleaning products passed through the hose, and the total time that the hose has been in service also the original order number and the Serial Number for the hose. The Customer may send its own witness to the examination if required. Aflex Hose will provide a Non-Conformance Report to the Customer. The Customer shall bear the cost of returning the Aflex Hose Products that have failed; provided, however, as set forth in Section 17 below, Aflex Hose shall reimburse the Customer for any shipping costs if it is determined that the failure is covered by the warranty set forth in Section 14.

Conditions of Sale Continued

(17) If Aflex Hose determines that the faulty materials or a manufacturing defect in the hose is responsible for the hose failure, Aflex Hose's maximum liability shall be the invoice value of the failed hose itself, or the invoice value of the whole customer order as determined by Aflex Hose in its sole discretion, along with any reasonable costs for removal and replacement of the hose, and costs for packing and despatching the failed hose back to Aflex Hose.

Untested Hose for Self Assembly by Customers

(18) Aflex Hose sometimes supplies "loose" hose, without end fittings attached to a Self Assembly Customer, who will then cut the hose to length and attach end fittings to make up Hose Assemblies for their own use, or for sale to their own customers.

(19) Unless the Customer requests, and Aflex Hose confirms that the 'loose' hose is pressure tested before supply, such testing is not normally applied by Aflex Hose, because this testing requirement is otherwise satisfied by the Self Assembly Customer during his own testing of the finished Hose Assemblies made up using the "loose" hose. Self Assembly Customers agree and acknowledge that they are solely responsible for carrying out hydrostatic pressure testing of 100% of such assemblies to 1¹/₂ times the Maximum Working Pressure (MWP) of the hose assembly as specified in the relevant Full Product Brochure before supply for end use, to validate both the hose and the end fitting attachment.

(20) When pressure testing braided hoses with a plastic or rubber outer cover, the cover will mask any signs of leakage for a time. The Customer agrees and acknowledges that after the hydrostatic pressure test, it is required to test each covered hose assembly with an internal helium gas pressure of 30 Bar (450 psi) for hose sizes up to 1" and 15 Bar (225 psi) for hose sizes above 1", with the hose assembly immersed in water to enable leak detection by gas bubbles, for a minimum test period of 5 minutes.

(21) The "Self Assembly" Customer agrees and acknowledges that it shall determine and approve the Design Suitability of the hose assemblies for their intended use before supply and that, except as set forth in Section 22, it shall indemnify and hold Aflex Hose harmless from any Claims and Losses arising from Design Suitability for a Self Assembly Customer. This includes proceeding in accordance with Section (7) and Section (8) above.

(22) Aflex Hose's liability is limited to Aflex Hose Products which are assembled by approved Self Assembly Customers if all the hose and fitting components were supplied by Aflex Hose or approved for use by Aflex Hose in writing, and they were assembled and tested in accordance with Aflex Hose's current Manufacturing and Testing Instructions, available to approved Self Assemblers in an I-Bay on the Aflex Hose website.

Untested Hose Assemblies

(23) Aflex Hose is sometimes requested by Customers to attach non-standard end fittings to hose assemblies which they, supply, and in some cases it is not possible to connect these fittings to the Aflex Hose pressure test system. In such cases a "concession not to test" is obtained from the Customer, and a label is attached to the hose assembly, warning that it requires pressure testing before use. The Customer agrees and acknowledges that Aflex Hose shall have no liability whatsoever if the Customer does not comply with the warning that requires pressure testing before use.

Force Majeure

(24) Aflex Hose shall not be liable for any delay in delivery, failure to deliver or default in performing in accordance with any Customer's order if the delay or default is due to: (a) fires, floods, strikes, or other labor disputes, accidents to Aflex Hose's production facilities, acts of sabotage, riots, natural disasters, difficulties procuring materials, shortages of raw materials, interference by civil or military authorities, whether legal or de facto, governmental restrictions, including but not limited to failure to obtain export licenses, delays in transportation or lack of transportation facilities, restrictions imposed by federal, state or other governmental legislation or, rules or regulations thereof, including a force majeure event occurring in respect to one of Aflex Hose's suppliers; or (b) any other cause beyond Aflex Hose's control.

Governing Law; Jurisdiction

(25) These Conditions of Sale and all rights, duties and obligations hereunder, including any and all other Customer agreements and orders shall be governed by and subject to English Law.

(26) The Customer acknowledges and agrees that any disputes arising out of or related in any way to this Agreement, including a breach of this Agreement, shall be brought exclusively in the courts of England, United Kingdom. Furthermore, Customer knowingly, voluntarily and irrevocably (a) consents to the exclusive jurisdiction of these courts, (b) waives any immunity or objection, including any objection to personal jurisdiction or the laying of venue or based on the grounds of forum non conveniens, which it may have from or to the bringing of the dispute in such jurisdiction, (c) waives any personal service of any summons, complaint or other process that may be made by any other means permitted by England, United Kingdom, (d) waives any right to trial by jury, (e) agrees that any such dispute will be decided by court trial without a jury, (f) understands that it is giving up valuable legal rights under this Section 26, including the right to trial by jury, and that it voluntarily and knowingly waives those rights.

Limitations of Liability

(27) Aflex Hose Products have not been designed or tested for use in aerospace, medical implantation or radioactive applications, and such use is therefore strictly prohibited unless written approval from Aflex Hose has been given. Customer agrees and acknowledges that it is aware of the limitations set forth in this Section 26 and hereby agrees that Aflex Hose shall not have any liability whatsoever in the event Customer uses Aflex Hose Products for aerospace, medical implantation or radioactive applications. Customer agrees to indemnify Aflex Hose, its officers, directors, employees, affiliates and representatives for any and all Claims and Losses arising out of Customer's use of the Aflex Hose Products for aerospace, medical implantation or radioactive applications.

(28) Aflex Hose will not accept liability for any failures of the Aflex Hose Products which are caused by Customers failing to perform their Responsibilities as specified in these Conditions of Sale.

(29) NOTWITHSTANDING ANYTHING TO THE CONTRARY HEREIN, IN NO EVENT SHALL AFLEX HOSE BE LIABLE FOR ANY SPECIAL, INDIRECT, INCIDENTAL, CONSEQUENTIAL, EXEMPLARY, OR PUNITIVE DAMAGES, LOSS OF PROFITS OR REVENUE, LOSS OF PROCESS PRODUCTS, DAMAGE TO EQUIPMENT, DOWNTIME COSTS, OR LOSS OF USE EVEN IF INFORMED OF THE POSSIBILITY OF SUCH DAMAGES. TO THE EXTENT PERMITTED BY APPLICABLE LAW, THESE EXCLUSIONS AND LIMITATIONS WILL APPLY REGARDLESS OF WHETHER LIABILITY ARISES FROM FAILURE OF THE PRODUCT(S), BREACH OF CONTRACT, FAILURE TO DELIVER ON TIME, WARRANTY, TORT (INCLUDING, BUT NOT LIMITED TO, NEGLIGENCE), BY OPERATION OF LAW, OR OTHERWISE.

Completion of Bulk Hose Orders

(30) Due to the nature of the production of PTFE hose, Aflex Hose reserves the right to call an order complete in the following situations. If a product is a standard Aflex product (as listed in Aflex product brochures) a figure of +10% of original order quantity can be supplied. If the product is a non-standard product and outside the Aflex standard product range the figure of +/- 10% of the original order quantity can be supplied. Goods supplied within these parameters would render the order complete.

Notice Provisions

(31) Any written notice required to be provided to Aflex Hose shall be sent to the following address: Aflex Hose Limited, Spring Bank Industrial Estate, Watson Mill Lane, Sowerby Bridge, Halifax, West Yorkshire, HX6 3BW.

Exclusion of CISG

(32) The United Nations Convention on Contracts for the International Sale of Goods shall not apply to these Conditions of Sale and any and all other Customer documents.



UK Corroflon/19.06.15 Rev 38

UK

Spring Bank Industrial Estate
Watson Mill Lane
Sowerby Bridge
Halifax
West Yorkshire, HX6 3BW

Tel: +44 (0) 1422 317200
Fax: +44 (0) 1422 836000

USA

6111 Kellers Church Road
Unit B
Pipersville,
Pa 18947

Tel: 215 - 766 - 1455
Fax: 215 - 766 - 1688

www.aflex-hose.com

